

EXPLOSION-PROOF PRESSURE, VACUUM, DIFFERENTIAL PRESSURE AND TEMPERATURE SWITCHES



- Meet global requirements with worldwide certifications and approvals
- Increase flexibility with multiple outputs
- Easy installation via dual electrical conduit openings
- Simplify wiring through easy-to-access terminal block
- Match process requirements with an assortment of available sensors
- Improve measurement accuracy with ultra-low pressure ranges



OVERVIEW

As safety requirements become more stringent, the determining factor in specifying an industrial pressure, differential pressure and/or temperature switch rests upon that switch protecting equipment, processes and personnel. Meeting hazardous location requirements through worldwide approvals and certifications, UE's 120 Series is the choice where potentially explosive or highly corrosive atmospheres exist.

The 120 Series offers a variety of pressure, vacuum, differential pressure and temperature ranges, as well as process connections, wetted materials and sensor types. With a common flexible platform, models can quickly be adapted at the factory for special requirements, such as ranges, process connections and electrical ratings. Typical industries using 120 Series switches include chemical, petrochemical, refinery and oil & gas production and transmission.

FEATURES

- Standard product approvals include cULus, ATEX & IECEx
- Optional approvals for Russia, Ukraine, China, India, Korea, Brazil and Taiwan
- Many models compliant to NACE MR-0175

- Internal adjustment hex screw or external adjustment via calibrated dial(s) with tamper-resistant cover
- Integral cover lock
- SPDT, DPDT or dual SPDT output
- Optional hermetically sealed micro-switch
- Wide variety of sensor materials
- Optional Hastelloy® and Monel® sensor material for corrosive media
- Wide adjustable deadband models
- Heat tracing temperature models



SPECIFICATIONS

STORAGE TEMPERATURE	-65 to 160°F (-54 to 71°C)
AMBIENT TEMPERATURE LIMITS	-58 to 160°F (-50 to 71°C); models 36-39, 520-525, 540-548, 701-705, 15834-15839: 0 to 160°F (-17 to 71°C); types 820E, 822E: -40 to 160°F (-40 to 71°C) set point typically shifts less than 1% of range for a 50°F (28°C) ambient temperature change; less than 2% for types E121 & E122
SET POINT REPEATABILITY	Temperature models: Type B, C and F: ±1% of full scale range Type E: ±2% of full scale range Pressure models 126-164, S126B-S164B, 171-174, 270-274, 358-376, 520-535, 540-543, 701-705, 15622, 15834,-15839: ±1% of full scale range; models 450-457, 550-559: ±1½% of full scale range; models 36-39, 183-194, 483-494, 544-548, 565-567, 612-680, 15875: ±1-1/2% of full scale range Set point repeats after 15 G, 10 millisecond duration
SHOCK	Set point repeats after 2.5 G, 5-500 Hz
VIBRATION	
ENCLOSURE	Die cast aluminum, epoxy powder coated; gasketed; cover lock; internal set point lock standard on types J, C, F; gasketed stainless steel tamper-resistant dial cover on types B, H, E; aluminum nameplate
ENCLOSURE CLASSIFICATION	Certified to enclosure type 4X. Class I, Division 1 product meets enclosure type 7; Class II, Division 1 product meets enclosure type 9. Certified to IP66 requirements
SWITCH OUTPUT	One or two SPDT; dual switch may be separated up to 100% of range; except type 822E where switch #2 can be set up to 25% of range span below switch #1 setpoint; switches may be wired "normally open" or "normally closed".
ELECTRICAL RATING*	15A 125/250/480 VAC resistive (standard), 2A @ 30 VDC, 1A @ 48 VDC, 0.5A @ 125 VDC; except types J120-15622, 15834-15839, H121-15875: 20A 125/250/480 VAC resistive, 6A @ 30 VDC, 0.5A @ 125 VDC, 0.25A @ 250 VDC; except types B121-13272, B122-13322, E121-13273, E122-13321: 22A 480 VAC resistive, 2A @ 30 VDC, 1A @ 48 VDC, 0.4A @ 125 VDC.
REFERENCE SCALES	Types B, E & H: external dial. Scale divisions vary with range (see model charts)
WEIGHT	3-8 lbs. Varies with type and model
ELECTRICAL CONNECTION	Type H, B, E; one 3/4" NPT E/C; type J, C, F, 820E, 822E; two 3/4" NPT E/C; terminal block standard
PRESSURE CONNECTION	Models S126B-S164B, 171-194, 483-494, 520-535: 1/2" NPT (female); models 565-567: 1-1/2" flush mount connection; models 540-548: 1/8" NPT (female); all others: 1/4" NPT (female)
TEMPERATURE ASSEMBLY	Bulb and capillary: 6 feet 304 stainless steel (standard) except for E121-13273 and E122-13321: 10 feet; Fill: Non-toxic oil filled Immersion stem: Nickel-plated brass (standard) except for B121-13272 and B122-13322: stainless steel.
TEMPERATURE DEADBAND	Type F120, 820E, 822E: typically 1%; type B-, C-, and E- 121 and 122: typically 2% of range under laboratory conditions (70°F [21°C] ambient circulating bath at rate of 1/2°F per minute change)
PRESSURE DEADBAND	See individual model charts on pages 6-14. Consult UE for deadbands on switch options
DIFFERENTIAL PRESSURE INDICATOR (OPTION M210)	Differential pressure indication available types H121K and H122K with option M210 (check model availability under options); accuracy approximately 1% mid 50% of range, 3% at ends; window is plexiglass and gasketed; indicator may be field adjusted for approximately ±1% accuracy at any set point within range
TEMPERATURE INDICATION	Temperature indication available types 820E and 822E. Indication accuracy is ±1% of adjustable range

*NOTE: DC Ratings are based on experience - Consult UE for further information. VDC ratings are not listed on nameplates.

AGENCY APPROVALS

UE declarations and third-party issued certifications are available for download at www.ueonline.com/certs

UNITED STATES AND CANADA



Class I, Division 1 and 2, Groups B, C & D
 Class II, Division 1 and 2, Groups E, F & G
 Class III
 Class I, Zone 1, Group IIB + H2 T6
 Enclosure Type 4X
 UL Listed, cUL Certified
 Pressure: UL 50 & 1203; CSA C22.2
 No. 25 & 30 - File # E40857
 Temperature: UL 50 & 1203; CSA C22.2
 No. 25 & 30 - File # E43374

Canadian registration number (CRN) for Canadian provinces can be found at www.ueonline.com

EUROPE



ATEX Directive (94/9/EC)

II 2 G Ex d IIC T6 Gb
 II 2 D Ex tb IIIC T85°C Db IP66
 Tamb = -40°C to +75°C
 UL International DEMKO A/S (N.B.# 0539)
 Certificate # DEMKO 09 ATEX 0815573X Rev. 2
 EN 60079-0, 60079-1, 60079-31
 II 1 G Ex ia IIC T6 Ga (OPTIONAL – code M405)
 (not available types 820E, 822E)
 Tamb = -50°C to +60°C
 UL International DEMKO A/S (N.B.# 0539)
 Certificate # DEMKO 11 ATEX 1105261 Rev. 0
 EN 60079-0, 60079-11, 60079-26



Pressure Equipment Directive (PED) (97/23/EC)

Compliant to PED
 Products rated lower than 7.5 psi are outside the scope of the PED

Low Voltage Directive (LVD) (2006/95/EC)

UEC compliant to LVD
 Products rated lower than 50 VAC and 75 VDC are outside of the scope of the LVD
 The Low Voltage Directive does not apply to products for use in hazardous locations

RUSSIA



К СЕРТИФИКАТУ СООТВЕТСТВИЯ (OPTIONAL – code M406)
 RU C-US.ГБ05.B.01185
 NANIO CCVE Certification Center
 Type 120, 121 and 122
 0Ex ia IIC T6 Ga X
 Tamb = -50°C to +60°C
 ГОСТ Р МЭК 60079-11, ГОСТ Р МЭК 60079-0-2011, ГОСТ 31610.26 / IEC 60079-26
 Type 120, 121, 122, 820 & 822
 1Ex d IIC T6 Gb X
 Tamb = -50°C to +80°C (models 120, 121 & 122)
 Tamb = -40°C to +75°C (models 820 & 822)
 ГОСТ Р МЭК IEC 60079-1, ГОСТ Р МЭК 60079-0

UKRAINE



Gosnadzorohrantruda Permit (OPTIONAL-code M404)
 СВДОЦТВО #720 by DVSTS VE (TCCExEE)
 1ExdIICT6X
 Tamb = -56°C to +85°C (types 120, 121 & 122)
 Tamb = -40°C to +71°C (types 820 & 822)
 ГОСТ 12.2.007.0, ГОСТ 22782.0, ГОСТ 22782.6

CHINA



CQST Certified (OPTIONAL – code M408)
 (120,121,122)Pressure: CNEEx15.2540X
 (120,121,122,820,822)Temperature: CNEEx15.2541X
 Ex d IIC T6 Gb
 Ex tD A21 T+85°C IP66
 Tamb. = -40°C to +75°C
 GB3836.1,GB3836.2 & GB12476.

AGENCY APPROVALS CONT.

INTERNATIONAL CERTIFICATION*
(INCLUDES AUSTRALIA)

IECEX Certified
 Ex d IIC T6 Gb
 Ex tb IIIC T85°C Db IP66
 Tamb. = -40°C to +75°C
 IEC 60079-0, 60079-1, 60079-31
 Certificate # IECEX UL 03.0001X
 Note: not available on Types 820E & 822E
 * See <http://www.iecex.com/countries.htm> for a list of participating members.

**BRAZIL**

INMETRO(OPTIONAL – code M391)
 Ex d IIC T6 Gb
 Ex tb IIIC T85°C Db IP66
 -40°C ≤ Ta ≤ +75°C
 UL-BR 15.0179X
 ABNT NBR IEC 60079-0
 ABNT NBR IEC 60079-1
 ABNT NBR IEC 60079-31
 Ex ia IIC T6 Ga
 -50°C ≤ Ta ≤ +60°C
 UL-BR 15.0169X
 ABNT NBR IEC 60079-0
 ABNT NBR IEC 60079-11
 ABNT NBR IEC 60079-26

INDIA

Ex d IIC T6 Gb
 PESO: CCEs Identification# P314108/1
 EN 60079-0, 60079-1
 Ex ia IIC T6 Ga (OPTIONAL – code M405)
 PESO: CCEs Identification# P305465/1
 EN 60079-0, 60079-11, 60079-26

**Taiwan**

ITRI
 Temperature Switch - ML041200701BZ4
 Pressure Switch – ML041200701AE7,
 ML041200701BY3, ML041200701C40,
 ML041200701D31

KOREA

KOSHA, Article 34 of Industrial Safety and Health Law
 (OPTIONAL – code M395)
 Ex d IIC T6
 -40°C < Tamb < +75°C
 Pressure: Certification# 10-AV4BO-0710
 Differential Pressure: Certification# 10-AV4BO-0711
 Temperature: Certification# 10-AV4BO-0712, 10-AV4BO-0713



PRESSURE MODEL CHART

• Type J120, single switch with internal adjustment, dual conduits

Model	Adjustable Set Point Range		Deadband		Over Range Pressure*		Proof Pressure**	
	Low end of range on fall; High end of range on rise "wc	mbar	"wc	mbar	psi	bar	psi	bar
Buna N diaphragm and O-Ring with epoxy coated aluminum, 1/2" NPT (female) pressure connection, large 0.72" orifice for clean-out purposes (other wetted materials available see pg. 18)								
520	300 Vac to 0	-746,7 to 0	0.2 to 8	0,5 to 19,9	100	6,9	100	6,9
521	10 Vac to 10	-24,9 to 24,9	0.1 to 0.6	0,2 to 1,5	100	6,9	100	6,9
522	50 Vac to 50	-124,5 to 124,5	0.1 to 3	0,2 to 7,5	100	6,9	100	6,9
523	0.5 to 5	1,2 to 12,4	0.1 to 0.3	0,2 to 0,7	100	6,9	100	6,9
524	2.5 to 50	6,2 to 124,5	0.1 to 0.8	0,2 to 2,0	100	6,9	100	6,9
525	10 to 250	24,9 to 622,3	0.1 to 6	0,2 to 14,9	100	6,9	100	6,9
Welded 316L stainless steel diaphragm and 1/2" NPT (female) pressure connection, large 0.72" orifice for clean-out purposes								
530	300 Vac to 0	-746,7 to 0	0.2 to 15	0,5 to 37,3	50	3,4	100	6,9
531	10 Vac to 10	-24,9 to 24,9	0.1 to 0.6	0,2 to 1,5	50	3,4	100	6,9
532	50 Vac to 50	-124,5 to 124,5	0.1 to 3	0,2 to 7,5	50	3,4	100	6,9
533	0.5 to 5	1,2 to 12,4	0.1 to 0.3	0,2 to 0,7	50	3,4	100	6,9
534	2.5 to 50	6,2 to 124,5	0.1 to 0.8	0,2 to 2,0	50	3,4	100	6,9
535	10 to 250	24,9 to 622,3	0.1 to 10	0,2 to 24,9	50	3,4	100	6,9
	psi	bar (unless noted)	psi	mbar (unless noted)	psi	bar	psi	bar
1.5" sanitary welded 316L stainless steel diaphragm and pressure connection. Mates with Tri-Clamp® fitting systems, (not UE supplied)								
565	5 to 30	0,3 to 2,1	1 to 5	68,9 mbar to 0,3 bar	1000	68,9	1500	103,4
566	10 to 100	0,7 to 6,9	1 to 12	68,9 mbar to 0,8 bar	1000	68,9	1500	103,4
567	15 to 300	1,0 to 20,7	3 to 22	0,2 to 1,5	1000	68,9	1500	103,4
Welded 316L stainless steel diaphragm and 1/2" NPT (female) pressure connection, large 0.72" orifice for clean-out purposes (NACE MR-0175 compliant)								
171	1 to 20	68,9 mbar to 1,4 bar	0.1 to 1	6,9 to 68,9	500	34,5	1000	68,9
172	2 to 50	0,1 to 3,4	0.1 to 1.5	6,9 to 103,4	500	34,5	1000	68,9
173	4 to 100	0,3 to 6,9	0.1 to 2.5	6,9 to 172,4	500	34,5	1000	68,9
174	8 to 200	0,6 to 13,8	0.1 to 3.5	6,9 to 241,3	500	34,5	1000	68,9

Application Note: The use of metallic diaphragms where higher pressure shock or heavy cycling is expected should be avoided. Models 171-174 should not be used where system or start-up vacuum might exceed 26 " Hg Vac

***Over Range Pressure:** The maximum pressure that may be applied continuously without causing damage and maintaining set point repeatability.

****Proof Pressure:** The maximum pressure to which a pressure sensor may be occasionally subjected, which causes no permanent damage. The unit may require calibration (e.g. start-up, testing)

PRESSURE MODEL CHART

• Type J120, single switch with internal adjustment, dual conduits (cont.)

Model	Adjustable Set Point Range		Deadband		Over Range Pressure*		Proof Pressure**	
	psi (unless noted)	bar (unless noted)	psi (unless noted)	bar (unless noted)	psi (unless noted)	bar (unless noted)	psi	bar
316L stainless steel diaphragm (optional Hastelloy® C 276 or Monel® 400); Viton® GLT O-Ring (optional Kalrez®, Ethylene Propylene or Aflas®); 316 stainless steel 1/2" NPT (female) pressure connection (optional Hastelloy® C 276 or Monel® 400), 0.72" orifice for clean-out purposes. Models 188 and 189 have a 316L stainless steel 1/2" NPT (female) pressure connection (NACE MR-0175 compliant)								
183	1 to 20	0,1 to 1,4	0.3 to 2.5	20,7 to 172,4 mbar	500	34,5	1000	68,9
184	2 to 50	0,1 to 3,4	0.3 to 3	20,7 to 206,8 mbar	500	34,5	1000	68,9
185	4 to 100	0,3 to 6,9	0.5 to 6	34,5 to 413,7 mbar	500	34,5	1000	68,9
186	8 to 200	0,6 to 13,8	1 to 11	0,1 to 0,8	500	34,5	1000	68,9
188	50 to 1000	3,4 to 68,9	25 to 125	1,7 to 8,6	2000	137,9	7000	482,6
189	250 to 3500	17,2 to 241,3	50 to 300	3,4 to 20,7	4000	275,8	7000	482,6
316L stainless steel diaphragm (optional Hastelloy® C 276 or Monel® 400); Viton®GLT O-Ring (optional Kalrez®, Ethylene Propylene or Aflas®); 316 stainless steel 1/2" NPT (female) pressure connection (optional Hastelloy® C 276 or Monel® 400), 0.06" orifice to dampen pulsations. Models 488 and 489 have a 316L stainless steel 1/2" NPT (female) pressure connection (NACE MR-0175 compliant)								
483	1 to 20	0,1 to 1,4	0.3 to 2.5	20,7 to 172,4 mbar	500	34,5	1000	68,9
484	2 to 50	0,1 to 3,4	0.3 to 3	20,7 to 206,8 mbar	500	34,5	1000	68,9
485	4 to 100	0,3 to 6,9	0.5 to 6	34,5 to 413,7 mbar	500	34,5	1000	68,9
486	8 to 200	0,6 to 13,8	1 to 11	0,1 to 0,8	500	34,5	1000	68,9
488	50 to 1000	3,4 to 68,9	25 to 125	1,7 to 8,6	2000	137,9	7000	482,6
489	250 to 3500	17,2 to 241,3	50 to 300	3,4 to 20,7	4000	275,8	7000	482,6
Welded 316L stainless steel bellows and 1/2" NPT (female) pressure connection								
S126B	30 to 3 "Hg Vac	-1 to -0,1	0.2 to 0.6 "Hg	6,8 to 20,3 mbar	80 "wc	199,1 mbar	5	0,3
S134B	30 "Hg Vac to 20 psi	-1 to 1,4	0.2 to 0.6 "Hg	6,8 to 20,3 mbar	20	1,4	25	1,7
S137B	15 to 80 "wc	37,3 to 199,1 mbar	2 to 6 "wc	5,0 to 14,9 mbar	80 "wc	199,1 mbar	5	0,3
S144B	0.5 to 20	34,5 mbar to 1,4 bar	0.1 to 0.3	6,9 to 20,7 mbar	20	1,4	25	1,7
S152B	1 to 50	0,1 to 3,4	0.1 to 0.5	6,9 to 34,5 mbar	50	3,4	75	5,2
S156B	2 to 100	0,1 to 6,9	0.2 to 0.6	13,8 to 41,4 mbar	100	6,9	125	8,6
S164B	4 to 200	0,3 to 13,8	0.2 to 1	13,8 to 68,9 mbar	200	13,8	200	13,8

Viton®, Kalrez®, and Teflon® are registered trademarks of E.I. duPont de Nemours and Company
 Monel® is a registered trademark of the Special Metals Corporation
 Tri-Clover and Tri-Clamp® is a registered trademark of Alfa Laval
 Hastelloy® is a registered trademark of Haynes International, Inc
 Aflas® is a registered trademark of Asahi Glass



120 Series

120 Series

PRESSURE MODEL CHART

• Type J120, single switch with internal adjustment, dual conduits (cont.)

Model	Adjustable Set Point Range		Deadband				Over Range Pressure*		Proof Pressure**	
	Low end of range on fall; High end of range on rise		Lower 75% range span		Top 25% range span		psi	bar	psi	bar
	psi	bar	psi	bar	psi	bar				
Welded 316 stainless steel diaphragm and 1/2" NPT (female) pressure connection, large 0.72" orifice for clean-out purposes (NACE MR-0175 compliant, except model 194)										
190	5 to 30	0,3 to 2,1	1 to 3	0,1 to 0,2	6 max	0,4	1500	103,4	2500	172,4
191	10 to 100	0,7 to 6,9	1 to 8	0,1 to 0,6	15 max	1,0	1500	103,4	2500	172,4
192	15 to 300	1,0 to 20,7	3 to 18	0,2 to 1,2	25 max	1,7	1500	103,4	2500	172,4
193	20 to 500	1,4 to 34,5	4 to 30	0,3 to 2,1	45 max	3,1	1500	103,4	2500	172,4
194	80 to 1700	5,5 to 117,2	5 to 120	0,3 to 8,3	150 max	10,3	2000	137,9	2500	172,4
Welded 316 stainless steel diaphragm and 1/2" NPT (female) pressure connection, 0.06" orifice to dampen pulsations (NACE MR-0175 compliant, except model 494)										
490	5 to 30	0,3 to 2,1	1 to 3	0,1 to 0,2	6 max	0,4	1500	103,4	2500	172,4
491	10 to 100	0,7 to 6,9	1 to 8	0,1 to 0,6	15 max	1,0	1500	103,4	2500	172,4
492	15 to 300	1,0 to 20,7	3 to 18	0,2 to 1,2	25 max	1,7	1500	103,4	2500	172,4
493	20 to 500	1,4 to 34,5	4 to 30	0,3 to 2,1	45 max	3,1	1500	103,4	2500	172,4
494	80 to 1700	5,5 to 117,2	5 to 120	0,3 to 8,3	150 max	10,3	2000	137,9	2500	172,4

Model	Adjustable Set Point Range		Deadband				Over Range Pressure*		Proof Pressure**	
	Low end of range on fall; High end of range on rise						psi	bar	psi	bar
	psi (unless noted)	bar (unless noted)	psi (unless noted)	bar (unless noted)	psi (unless noted)	bar (unless noted)				
Brass bellows with nickel-plated brass 1/4" NPT (female) pressure connection; models 126 & 134 have zinc-plated steel spring which is exposed to media										
126	30 to 3 "Hg Vac	-1 to -0,1	0.2 to 0.6 "Hg	6,8 to 20,3 mbar	80 "wc	199,1 mbar	5	0,3		
134	30 "Hg Vac to 20 psi	-1 to 1,4	0.2 to 0.6 "Hg	6,8 to 20,3 mbar	20	1,4	25	1,7		
137	15 to 80 "wc	37,3 to 199,1 mbar	2 to 6 "wc	5,0 to 14,9 mbar	80 "wc	199,1 mbar	5	0,3		
144	0.5 to 20	34,5 mbar to 1,4 bar	0.1 to 0.3	6,9 to 20,7 mbar	20	1,4	25	1,7		
152	1 to 50	0,1 to 3,4	0.1 to 0.5	6,9 to 34,5 mbar	50	3,4	75	5,2		
156	2 to 100	0,1 to 6,9	0.2 to 0.6	13,8 to 41,4 mbar	100	6,9	125	8,6		
164	4 to 200	0,3 to 13,8	0.2 to 1	13,8 to 68,9 mbar	200	13,8	200	13,8		
Welded 316L stainless steel bellows and 1/4" NPT (female) pressure connection										
356	15 to 100	1,0 to 6,9	0.7 to 1.8	48,3 to 124,1 mbar	100	6,9	800	55,2		
358	15 to 200	1,0 to 13,8	1 to 6	0,1 to 0,4	200	13,8	800	55,2		
361	20 to 300	1,4 to 20,7	1 to 7	0,1 to 0,5	300	20,7	800	55,2		
376	25 to 500	1,7 to 34,5	1.5 to 8	0,1 to 0,6	500	34,5	800	55,2		
Phosphor bronze bellows with nickel-plated brass 1/4" NPT (female) pressure connection										
270	4 to 200	0,3 to 13,8	1 to 4	0,1 to 0,3	200	13,8	250	17,2		
274	6 to 300	0,4 to 20,7	1 to 5	0,1 to 0,3	300	20,7	350	24,1		

*Over Range Pressure: The maximum pressure that may be applied continuously without causing damage and maintaining set point repeatability.

**Proof Pressure: The maximum pressure to which a pressure sensor may be occasionally subjected, which causes no permanent damage. The unit may require calibration (e.g. start-up, testing)

Deadband note: Models 190-194, 490-494 are expressed as the lower 75 % and top 25% of the range span because of the operating characteristics of the diaphragm sensor and switch.

PRESSURE MODEL CHART

• Type J120, single switch with internal adjustment, dual conduits (cont.)

Model	Adjustable Set Point Range		Deadband		Over Range Pressure*		Proof Pressure**	
	psi (unless noted)	bar (unless noted)	psi (unless noted)	bar (unless noted)	psi (unless noted)	bar (unless noted)	psi	bar
303 stainless steel piston with Buna N O-Ring and 303 stainless steel 1/4" NPT (female) pressure connection (not recommended for gas service since drying of the O-Ring seal can allow bleeding of medium into the atmosphere)								
612	125 to 3000	8,6 to 206,8	40 to 250	2,8 to 17,2	6000	413,7	10000	689,5
616	700 to 5000	48,3 to 344,7	40 to 375	2,8 to 25,9	6000	413,7	10000	689,5
316 stainless steel bellows and 1/4" NPT (female) pressure connection (not recommended for rapid or high cycling pressure changes)								
680	100 to 1700	6,9 to 117,2	9 to 40	0,6 to 2,8	1700	117,2	2500	172,4
Buna N diaphragm and O-Ring with nickel-plated brass 1/4" NPT (female) pressure connection; Optional Viton diaphragm and O-Ring available								
701	1.5 to 30	103,4 mbar to 2,1 bar	1 to 2	68,9 mbar to 0,1 bar	500	34,5	1000	68,9
702	3 to 100	0,2 to 6,9	1 to 5	68,9 to 0,3 bar	500	34,5	1000	68,9
703	9 to 300	0,6 to 20,7	1 to 7	68,9 to 0,5 bar	500	34,5	1000	68,9
704	15 to 500	1,0 to 34,5	2 to 11	0,1 to 0,8	1500	103,4	2500	172,4
705	30 to 1000	2,1 to 68,9	3 to 22	0,2 to 1,5	1500	103,4	2500	172,4
Buna N diaphragm and O-Ring with 1/4" NPT (female) stainless steel connection and cap								
450	30 "Hg Vac to 3 "Hg Vac	-1 to -0,1	0.1 to 0.3 "Hg	3,4 to 10,2 mbar	80 "wc	199,1 mbar	225	15,5
452	30 "Hg Vac to 20 psi	-1,0 to 1,4	0.1 to 0.4 "Hg	3,4 to 13,5 mbar	20	1,4	225	15,5
Buna N diaphragm and O-Ring with 1/4" NPT (female) aluminum connection and cap								
451	2 to 80" wc	5 to 199,1 mbar	0.8 to 2 "wc	2 to 5 mbar	80 "wc	199,1 mbar	225	15,5
453	0.5 to 20	34,5 mbar to 1,4 bar	0.05 to 0.1	3,4 to 6,9 mbar	20	1,4	225	15,5
454	0.8 to 30	55,2 mbar to 2,1 bar	0.05 to 0.2	3,4 to 13,8 mbar	30	2,1	225	15,5
Teflon® diaphragm and Viton O-Ring 316 stainless steel with 1/4" NPT (female) 316 stainless steel pressure connection and cap								
550	30 "Hg Vac to 3 "Hg Vac	-1 to -0,1	0.1 to 0.4 "Hg	3,4 to 13,5 mbar	80 "wc	199,1 mbar	225	15,5
551	2 to 80 "wc	5 to 199,1 mbar	1 to 4 "wc	2,5 to 10 mbar	80 "wc	199,1 mbar	225	15,5
552	30 "Hg Vac to 20 psi	-1,0 to 1,4	0.2 to 0.5 "Hg	6,8 to 16,9 mbar	20	1,4	225	15,5
553	0.5 to 20	34,5 mbar to 1,4 bar	0.1 to 0.2	6,9 to 13,8 mbar	20	1,4	225	15,5
554	0.8 to 30	55,2 mbar to 2,1 bar	0.1 to 0.3	6,9 to 20,7 mbar	30	2,1	225	15,5
555	2 to 100	0,1 to 6,9	0.2 to 0.4	13,8 to 27,6 mbar	100	6,9	225	15,5

*Over Range Pressure: The maximum pressure that may be applied continuously without causing damage and maintaining set point repeatability.

**Proof Pressure: The maximum pressure to which a pressure sensor may be occasionally subjected, which causes no permanent damage. The unit may require calibration (e.g. start-up, testing)

PRESSURE MODEL CHART

• Type J120, single switch with internal adjustment, dual conduits with adjustable deadband micro-switch[†]

Model	Adjustable Set Point Range		Adjustable Deadband						Over Range Pressure*		Proof Pressure**	
	Low end of range on fall; High end of range on rise		Low end		Mid Range		High End		psi	bar	psi	bar
	psi	bar	psi	bar	psi	bar	psi	bar	psi	bar	psi	bar
	(unless noted)		(unless noted)		(unless noted)		(unless noted)		(unless noted)		(unless noted)	
Viton® diaphragm and O-ring with 1/4" NPT (female) 316 stainless steel pressure connection												
15622	20 to 200	1,4 to 13,8	12 to 26	0,8 to 1,8					500	34,5	1000	68,9
Buna N diaphragm and O-Ring with nickel-plated brass 1/4" NPT (female) pressure connection												
15834	3 to 30	0,2 to 2,1	1,5 to 4	0,1 to 0,3	2 to 4,5	0,1 to 0,3	2,5 to 5	0,2 to 0,3	500	34,5	1000	68,9
15835	5 to 100	0,3 to 6,9	3 to 6	0,2 to 0,4	4 to 7,5	0,3 to 0,5	5 to 9	0,3 to 0,6	500	34,5	1000	68,9
15836	9 to 300	0,6 to 20,7	4 to 11	0,3 to 0,8	5 to 13	0,3 to 0,9	5 to 16	0,3 to 1,1	500	34,5	1000	68,9
15837	15 to 500	1 to 34,5	8 to 25	0,6 to 1,7	9 to 28	0,6 to 1,9	10 to 31	0,7 to 2,1	1500	103,4	2500	172,4
15838	30 to 1000	2,1 to 68,9	9 to 30	0,6 to 2,1	10 to 35	0,7 to 2,4	30 to 90	2,1 to 6,2	1500	103,4	2500	172,4
15839	100 to 1700	6,9 to 117,2	25 to 60	1,7 to 4,1	40 to 80	2,8 to 5,5	50 to 100	3,4 to 6,9	2000	137,9	2500	172,4

• H121, single switch with external adjustment via reference dial, single conduit with adjustable deadband micro-switch

Model	Adjustable Set Point Range		Adjustable Deadband						Proof Pressure**		Dial Divisions
	Low end of range on fall; High end of range on rise		Low end		Mid Range		High End		psi	bar	psi
	psi	bar	psi	bar	psi	bar	psi	bar	psi	bar	psi
303 stainless steel piston with Buna N O-Ring and 303 stainless steel 1/4" NPT (female) pressure connection, includes adjustable deadband micro-switch (not recommended for gas service since drying of the O-Ring seal can allow bleeding of medium into the atmosphere)											
15875 ^{††}	500 to 6000	34,5 to 413,7	150 to 400	10,3 to 27,6	250 to 500	17,2 to 34,5	450 to 750	31,0 to 51,7	10,000	689,5	100

*Over Range Pressure: The maximum pressure that may be applied continuously without causing damage and maintaining set point repeatability.

**Proof Pressure: The maximum pressure to which a pressure sensor may be occasionally subjected, which causes no permanent damage. The unit may require calibration (e.g. start-up, testing)

[†] Switch options listed on page 17-18 not available with these models

^{††} Not available on type H122

PRESSURE MODEL CHART

- Type H121, single switch with external adjustment via reference dial, single conduit
- Type H122, dual switch with external adjustment via reference dial, single conduit

Model	Adjustable Set Point Range		Deadband		Proof Pressure**		Dial Divisions
	Low end of range on fall; High end of range on rise		psi	bar	psi	bar	psi
	(unless noted)	(unless noted)	(unless noted)	(unless noted)	(unless noted)	(unless noted)	(unless noted)
Welded 316L stainless steel bellows and 1/2" NPT (female) pressure connection							
S126B	30 "Hg Vac to 0 psi	-1 to 0	0.2 to 0.9 "Hg	6,8 to 30,5 mbar	5	0,3	0.5 "Hg
S134B	30 "Hg Vac to 20 psi	-1 to 1,4	0.2 to 1.2 "Hg	6,8 to 40,6 mbar	25	1,7	1 "Hg & 0.5 psi
S137B†	2 to 80 "wc	5 to 199,1 mbar	2 to 10 "wc	5 to 24,9 mbar	5	0,3	2 "wc
S144B	0 to 20	0 to 1,4	0.1 to 0.5	6,9 to 34,5 mbar	25	1,7	0.5
S146B	0 to 30	0 to 2,1	0.1 to 0.6	6,9 to 41,4 mbar	40	2,8	0.5
S156B	0 to 100	0 to 6,9	0.2 to 0.8	13,8 to 55,2 mbar	125	8,6	2
S164B	0 to 200	0 to 13,8	0.3 to 2	20,7 to 137,9 mbar	200	13,8	5
Brass bellows with nickel-plated brass 1/4" NPT (female) pressure connection; models 126 & 134 have a zinc-plated steel spring which is exposed to media							
126	30 "Hg Vac to 0 psi	-1 to 0	0.2 to 0.9 "Hg	6,8 to 30,5 mbar	5	0,3	0.5 "Hg
134	30 "Hg Vac to 20 psi	-1 to 1,4	0.2 to 1.2 "Hg	6,8 to 40,6 mbar	25	1,7	1 "Hg & 0.5 psi
137†	2 to 80 "wc	5 to 199,1 mbar	2 to 10 "wc	5 to 24,9 mbar	5	0,3	2 "wc
144	0 to 20	0 to 1,4	0.1 to 0.5	6,9 to 34,5 mbar	25	1,7	0.5
146	0 to 30	0 to 2,1	0.1 to 0.6	6,9 to 41,4 mbar	40	2,8	0.5
156	0 to 100	0 to 6,9	0.2 to 0.8	13,8 to 55,2 mbar	125	8,6	2
164	0 to 200	0 to 13,8	0.3 to 2	20,7 to 137,9 mbar	200	13,8	5
316L stainless steel bellows and 1/4" NPT (female) pressure connection							
358	0 to 200	0 to 13,8	1.5 to 8	0,1 to 0,6	250	17,2	5
361	0 to 300	0 to 20,7	2 to 9	0,1 to 0,6	350	24,1	10
376	0 to 500	0 to 34,5	3 to 12	0,2 to 0,8	575	39,6	10
303 stainless steel piston with Buna N O-Ring and 303 stainless steel 1/4" NPT (female) pressure connection (not recommended for gas service since drying of the O-Ring seal can allow bleeding of medium into the atmosphere)							
612	200 to 3000	13,8 to 206,8	40 to 250	2,8 to 17,2	10,000	689,5	50
614	500 to 6000	34,5 to 413,7	50 to 400	3,4 to 27,6	10,000	689,5	100

**Proof Pressure: The maximum pressure to which a pressure sensor may be occasionally subjected, which causes no permanent damage. The unit may require calibration (e.g. start-up, testing)

†Not available on type H122

PRESSURE MODEL CHART

- **Type H121, single switch with external adjustment via reference dial, single conduit**
- **Type H122, dual switch with external adjustment via reference dial, single conduit**

Model	Adjustable Set Point Range		Deadband		Proof Pressure**		Dial Divisions
	psi (unless noted)	bar	psi (unless noted)	bar (unless noted)	psi	bar	
Phosphor bronze bellows with nickel-plated brass 1/4" NPT (female) pressure connection							
270	0 to 200	0 to 13,8	1.5 to 8	0,1 to 0,6	250	17,2	5
274	0 to 300	0 to 20,7	2 to 10	0,1 to 0,7	350	24,1	10
Buna N diaphragm and O-Ring with stainless steel 1/4" NPT (female) pressure connection and cap							
450	30 "Hg Vac to 0 psi	-1 to 0	0.1 to 0.4 "Hg	3,4 to 13,5 mbar	225	15,5	0.5 "Hg
452	30 "Hg Vac to 20 psi	-1 to 1,4	0.1 to 1 "Hg	3,4 to 33,9 mbar	225	15,5	1 "Hg & 0.5 psi
Buna N diaphragm and O-Ring with aluminum 1/4" NPT (female) pressure connection and cap							
453	0 to 20	0 to 1,4	0.05 to 0.2	3,4 to 13,8 mbar	225	15,5	0.5
454	0 to 30	0 to 2,1	0.05 to 0.3	3,4 to 20,7 mbar	225	15,5	0.5
Teflon® diaphragm and Viton O-Ring with 316 stainless steel 1/4" NPT (female) pressure connection and cap							
550	30 "Hg Vac to 0 psi	-1 to 0	0.1 to 0.6 "Hg	3,4 to 20,3 mbar	225	15,5	0.5 "Hg
552	30 "Hg Vac to 20 psi	-1 to 1,4	0.2 to 1 "Hg	6,8 to 33,9 mbar	225	15,5	1 "Hg & 0.5 psi
553	0 to 20	0 to 1,4	0.05 to 0.3	3,4 to 20,7 mbar	225	15,5	0.5
554	0 to 30	0 to 2,1	0.1 to 0.4	6,9 to 27,6 mbar	225	15,5	0.5
555	0 to 100	0 to 6,9	0.25 to 0.75	17,2 to 51,7 mbar	225	15,5	2
Buna N diaphragm and O-Ring with nickel-plated brass 1/4" NPT (female) pressure connection; Optional Viton diaphragm and O-Ring available (models 701-703)							
701+	3 to 30	0,2 to 2,1	1 to 3	0,1 to 0,2	1000	68,9	0.5
702	10 to 100	0,7 to 6,9	1 to 5	0,1 to 0,3	1000	68,9	2
703	30 to 300	2,1 to 20,7	2 to 7	0,1 to 0,5	1000	68,9	10
704	50 to 500	3,4 to 34,5	3 to 12	0,2 to 0,8	2500	172,4	10
705	200 to 1000	13,8 to 68,9	5 to 25	0,3 to 1,7	2500	172,4	25

****Proof Pressure:** The maximum pressure to which a pressure sensor may be occasionally subjected, which causes no permanent damage. The unit may require calibration (e.g. start-up, testing)

[†]Not available on type H122

DIFFERENTIAL PRESSURE MODEL CHART

• Type J120K, single switch with internal adjustment, dual conduits

Model	Adjustable Set Point Range Low end of range on fall; High end of range on rise		Deadband		Working Pressure***		Proof Pressure**	
	psid (unless noted)	bar (unless noted)	psi (unless noted)	bar (unless noted)	psi (unless noted)	bar	psi	bar
Welded 316L stainless steel bellows and 1/2" NPT (female) pressure connections								
S147B	3 to 30	0,2 to 2,1	0.3 to 1.5	20,7 to 103,4 mbar	30 "Hg Vac to 100	-1 to 6,9	300	20,7
S157B	10 to 100	0,7 to 6,9	0.5 to 2	34,5 to 137,9 mbar	30 "Hg Vac to 180	-1 to 12,4	300	20,7
Welded brass bellows with nickel-plated brass 1/4" NPT (female) pressure connections								
147	3 to 30	0,2 to 2,1	0.3 to 1.5	20,7 to 103,4 mbar	30 "Hg Vac to 100	-1 to 6,9	180	12,4
157	10 to 100	0,7 to 6,9	0.5 to 2	34,5 to 137,9 mbar	30 "Hg Vac to 150	-1 to 10,3	180	12,4
Welded 316L stainless steel bellows and 1/4" NPT (female) pressure connections								
367	10 to 100	0,7 to 6,9	4 to 10	0,3 to 0,7	0 to 350	0 to 24,1	500	34,5
Buna N diaphragm and O-Ring with 316 stainless steel 1/4" NPT (female) pressure connections								
36	3 to 30	0,2 to 2,1	1 to 5	0,1 to 0,3	0 to 350	0 to 24,1	1000	68,9
37	10 to 100	0,7 to 6,9	2 to 8	0,1 to 0,6	0 to 500	0 to 34,5	1000	68,9
38	30 to 300	2,1 to 20,7	2 to 15	0,1 to 1,0	0 to 1000	0 to 68,9	2500	172,4
39	50 to 500	3,4 to 34,5	3 to 20	0,2 to 1,4	0 to 1000	0 to 68,9	2500	172,4
Buna N diaphragm and O-Ring with aluminum 1/4" NPT (female) pressure connections								
455	5 to 80 "wcd	12,4 to 199,1 mbar	1 to 4 "wc	2,5 to 10 mbar	30 "Hg Vac to 225	-1 to 15,5	225	15,5
456	2 to 20	0,1 to 1,4	0.1 to 0.3	6,9 to 20,7 mbar	30 "Hg Vac to 225	-1 to 15,5	225	15,5
457	3 to 30	0,2 to 2,1	0.1 to 0.4	6,9 to 27,6 mbar	30 "Hg Vac to 225	-1 to 15,5	225	15,5
Teflon® and Buna N diaphragms, Buna N O-Ring with aluminum 1/4" NPT (female) pressure connections								
559	10 to 100	0,7 to 6,9	0.2 to 1	13,8 to 68,9 mbar	30 "Hg Vac to 225	-1 to 15,5	225	15,5
Buna N diaphragm and sealing diaphragms with aluminum 1/8" NPT (female) pressure connections								
540	0.2 to 7 "wcd	0,5 to 17,4 mbar	0.05 to 0,6 "wc	0,1 to 1,5 mbar	30 "Hg to 200	-1 to 13,8	400	27,6
541	1 to 20 "wcd	2,5 to 49,8 mbar	0.1 to 1.0 "wc	0.2 to 2,5 mbar	30 "Hg to 200	-1 to 13,8	400	27,6
542	5 to 50 "wcd	12,4 to 124,5 mbar	0.2 to 2.5 "wc	0,5 to 6,2 mbar	30 "Hg to 200	-1 to 13,8	400	27,6
543	10 to 200 "wcd	24,9 to 497,8 mbar	0.5 to 8 "wc	1,2 to 19,9 mbar	30 "Hg to 200	-1 to 13,8	400	27,6
544	2 to 20	0,1 to 1,4	0.1 to 1.3	6,9 to 89,6 mbar	30 "Hg to 1200	-1 to 82,7	2500	172,4
545	5 to 50	0,3 to 3,4	0.2 to 2.2	13,8 mbar to 0,1 bar	30 "Hg to 1200	-1 to 82,7	2500	172,4
546	10 to 125	0,7 to 8,6	0.4 to 5.0	27,6 mbar to 0,3 bar	30 "Hg to 1200	-1 to 82,7	2500	172,4
547	50 to 250	3,4 to 17,2	0.8 to 10	0,1 to 0,7	30 "Hg to 1200	-1 to 82,7	2500	172,4
548	100 to 500	6,9 to 34,5	2.0 to 15	0,1 to 1,0	30 "Hg to 1200	-1 to 82,7	2500	172,4

**Proof Pressure: The maximum pressure to which a pressure sensor may be occasionally subjected, which causes no permanent damage. The unit may require calibration (e.g. start-up, testing)

***Working Pressure Range: The pressure range within which two opposing sensors can be safely operated and still maintain set point adjustability.

DIFFERENTIAL PRESSURE MODEL CHART

- **Type H121K, single switch with external adjustment dial via reference dial, single conduit**
- **Type H122K, dual switch with external adjustment dial via reference dial, single conduit**

Model	Adjustable Set Point Range		Deadband		Working Pressure***		Proof Pressure**		Dial Divisions
	Low end of range on fall; High end of range on rise psid	bar	psi	mbar	psi (unless noted)	bar	psi	bar	psi
Welded 316L stainless steel bellows and 1/2" NPT (female) pressure connections									
S147B	3 to 30	0,2 to 2,1	0.3 to 2	20,7 to 137,9	30 "Hg Vac to 100	-1 to 6,9	300	20,7	0.5
S157B	10 to 100	0,7 to 6,9	0.5 to 3	34,5 to 206,8	30 "Hg Vac to 180	-1 to 12,4	300	20,7	2
Brass bellows with nickel-plated brass 1/4" NPT (female) pressure connections									
147	3 to 30	0,2 to 2,1	0.3 to 2	20,7 to 137,9	30 "Hg Vac to 100	-1 to 6,9	180	12,4	0.5
157	10 to 100	0,7 to 6,9	0.5 to 3	34,5 to 206,8	30 "Hg Vac to 150	-1 to 10,3	180	12,4	2
Buna N diaphragm, O-Ring with aluminum 1/4" NPT (female) pressure connections									
456	2 to 20	0,1 to 1,4	0.1 to 0.3	6,9 to 20,7	30 "Hg Vac to 225	-1 to 15,5	225	15,5	0.5
457	3 to 30	0,2 to 2,1	0.1 to 0.4	6,9 to 27,6	30 "Hg Vac to 225	-1 to 15,5	225	15,5	0.5
Teflon® and Buna N diaphragms, Buna N O-Ring with aluminum 1/4" NPT (female) pressure connections									
559	10 to 100	0,7 to 6,9	0.2 to 1	13,8 to 68,9	30 "Hg Vac to 225	-1 to 15,5	225	15,5	2

****Proof Pressure:** The maximum pressure to which a pressure sensor may be occasionally subjected, which causes no permanent damage. The unit may require calibration (e.g. start-up, testing)

*****Working Pressure Range:** The pressure range within which two opposing sensors can be safely operated and still maintain set point adjustability.



Differential Pressure Indicating Option M210

TEMPERATURE MODEL CHART

- **Type B121, single switch, immersion stem, external adjustment via reference dial, single conduit**
- **Type B122, dual switch, immersion stem, external adjustment via reference dial, single conduit**
- **Type C120, single switch, immersion stem, internal adjustment, dual conduits**
- **Type E121, single switch, bulb and capillary, external adjustment via reference dial, single conduit**
- **Type E122, dual switch, bulb and capillary, external adjustment via reference dial, single conduit**
- **Type F120, single switch, bulb and capillary, internal adjustment, dual conduits**

Model	Adjustable Set Point Range		Max. Temp.		Scale Div.		Stem or Bulb Size* / Finish**
	°F	°C	°F	°C	°F	°C	
Type B121, single switch, immersion stem, external adjustment via reference dial. Type B122, dual switch, immersion stem, external adjustment via reference dial. Type C120, single switch, immersion stem, internal adjustment							
120	0 to 225	-17.8 to 107.2	275	135	5†	5†	9/16" x 1-7/8" below thread, 1/2" NPT nickel-plated brass
121	200 to 425	93.3 to 218.3	475	246.1	5†	5†	9/16" x 1-7/8" below thread, 1/2" NPT nickel-plated brass
13272 (B121) 13322 (B122) (Heat Tracing)	15 to 140	-9.4 to 60	160	71.1	2†	2†	9/16" x 2-11/16" long stainless steel
Type E121, single switch, bulb and capillary, external adjustment via reference dial. Type E122, dual switch, bulb and capillary, external adjustment via reference dial							
2BSA	-120 to 100	-84.4 to 37.8	150	65.6	5	5	3/8 x 2-5/8"
2BSB	30 to 250	-1.1 to 121.1	300	148.9	5	5	3/8 x 2-5/8"
3BS	100 to 400	37.8 to 204.4	450	232.2	5	5	3/8 x 2-1/8"
4BS	25 to 100	-3.9 to 37.8	150	65.6	2	1	3/8 x 6-3/4"
5BS	-20 to 80	-28.9 to 26.7	130	54.4	2	2	3/8 x 5"
8BS	350 to 640	176.7 to 337.8	690	365.6	5	5	3/8 x 3-1/4"
13273 (E121) 13321 (E122) (Heat Tracing)	25 to 325	-3.9 to 162.8	360	182.2	5	5	1/4" x 9-1/2"
Type F120, single switch, bulb and capillary, internal adjustment							
2BS	-125 to 350	-87.2 to 176.7	400	204.4	N/A	N/A	3/8 x 2-5/8"
3BS	-125 to 500	-87.2 to 260	550	287.8	N/A	N/A	3/8 x 2-1/8"
4BS	-40 to 120	-40 to 48.9	170	76.7	N/A	N/A	3/8 x 6-3/4"
5BS	-40 to 180	-40 to 82.2	230	110	N/A	N/A	3/8 x 5"
6BS	0 to 250	-17.8 to 121.1	300	148.9	N/A	N/A	3/8 x 4-1/2"
7BS	0 to 400	-17.8 to 204.4	450	232.2	N/A	N/A	3/8 x 3"
8BS	50 to 650	10 to 343.3	700	371.1	N/A	N/A	3/8 x 3-1/4"

† Types B121, B122 only.

***Optional immersion** stem lengths and capillary lengths are available – consult UE. Standard capillary length is 6 FT except HTFP models which are 10 FT.

****Optional stainless steel immersion** stem, and **stainless steel armored** or **Teflon covered capillary** available – consult UE.



INDICATING TEMPERATURE CONTROL MODEL CHART

- **Type 820E, single switch, external adjustment and temperature indication, dual conduits**
- **Type 822E, dual switch, external adjustment and temperature indication, dual conduits**

Model	Adjustable Set Point Range		Max. Temp.		Scale Div.		Bulb Size
	°F	°C	°F	°C	°F	°C	OD x Length
2BS	-125 to 350	-87.2 to 176.7	400	204.4	10	5	3/8 x 2-5/8"
3BS	-125 to 500	-87.2 to 260	550	287.8	10	5	3/8 x 2-1/8"
4BS	-40 to 120	-40 to 48.9	170	76.7	5	2	3/8 x 6-3/4"
5BS	-40 to 180	-40 to 82.2	230	110	5	2	3/8 x 5"
6BS	0 to 250	-17.8 to 121.1	300	148.9	5	2	3/8 x 4-1/2"
7BS	0 to 400	-17.8 to 204.4	450	232.2	10	5	3/8 x 3"
8BS	50 to 650	10 to 343.3	700	371.1	10	10	3/8 x 3-1/4"

Standard capillary length is 6ft. optional lengths and capillary protection available – consult UE.



HOW TO ORDER

BUILDING A PART NUMBER

Select a **Type**

Refer to the "Type" section below.
Determine type number based on switch output, enclosure, adjustment and reference.
Fill in the type portion of your part number with the corresponding number.

Select a **Model**

Refer to the "Model Charts"
Determine model based on adjustable range, deadband and proof pressure.
Fill in the model portion of your part number with the corresponding number.

Select an **Option**

Refer to the "Options" section
Determine option number based on switch output, optional materials or other product enhancements.
Fill in the option portion of your part number with the corresponding number.
Leave "option" portion blank if no options are needed. FOR MULTIPLE OPTIONS: Call United Electric Controls.

TYPE	DESCRIPTION
Pressure	Type J120 - One SPDT; epoxy coated enclosure; internal adjustment with no reference scale, dual conduits Type H121 - One SPDT; epoxy coated enclosure; external adjustment with reference dial , single conduit Type H122 - Two SPDT; epoxy coated enclosure; external adjustment with reference dial , single conduit
Differential Pressure	Type J120K - One SPDT; epoxy coated enclosure; internal adjustment with no reference scale , dual conduits Type H121K - One SPDT; epoxy coated enclosure; external adjustment with reference dial , single conduit Type H122K - Two SPDT; epoxy coated enclosure; external adjustment with reference dial , single conduit
Temperature	Type B121 - Immersion stem; one SPDT; epoxy coated enclosure; external adjustment with reference dial , single conduit Type B122 - Immersion stem; two SPDT; epoxy coated enclosure; external adjustment with reference dial , single conduit Type C120 - Immersion stem; one SPDT; epoxy coated enclosure; internal adjustment with no reference scale , dual conduits Type E121 - Bulb and capillary; one SPDT; epoxy coated enclosure; external adjustment with reference dial , single conduit Type E122 - Bulb and capillary; two SPDT; epoxy coated enclosure; external adjustment with reference dial , single conduit Type F120 - Bulb and capillary; one SPDT; epoxy coated enclosure; internal adjustment with no reference dial , dual conduits Type 820E - Bulb and capillary; one SPDT; external adjustment and temperature indication , dual conduits Type 822E - Bulb and capillary; two SPDT; external adjustment and temperature indication , dual conduits

SWITCH OPTIONS 1, 2, 3

0140	Gold contacts, 1A 125 VAC resistive, NOT AVAILABLE TYPE 820E & 822E
0500	Close deadband. 5A 125/250 VAC resistive. 3A, 28 VDC; 1A, 48 VDC; 0.5A, 125 VDC resistive. NOT AVAILABLE TYPES 820E, 822E AND MODELS 520-535, 540-548
1010	DPDT switch 10A 125/250 VAC resistive. 0.5A, 125 VDC; 0.25A, 250 VDC resistive. Deadband and minimum set point will increase. NOT AVAILABLE TEMPERATURE VERSIONS; TYPES H122, H122K; OR MODELS 36-39, 367 AND 540-548; OR J120 MODELS 171-194, 483-494, 520-535, 565-567, 680.
1070	10A, 125 VAC and VDC resistive. Deadband and minimum set point will increase. NOT AVAILABLE TYPES 820E, 822E, H122K, B122, AND J120K MODELS 36-39, 367 AND 540-548; OR J120 MODELS 171-194, 483-494, 520-535, 565-567, 680.
1180	Hermetically sealed with gold flash contacts. SPDT. 11A 125/250 VAC resistive. 5A, 30 VDC; 1A, 48 VDC; 0.5A, 125 VDC resistive. Deadband and minimum set point will increase. NOT AVAILABLE TYPES B122, E122, H122, H121K, 820 AND 822E.
1190	Hermetically sealed with gold flash contacts. DPDT. 11A, 125/250 VAC resistive. 5A, 30 VDC; 1A, 48 VDC; 0.5A, 125 VDC resistive. Products set on rising pressure or temperature due to inherent separation of circuits on falling pressure or temperature. Specify option 1195 if setting on fall is required. Deadband and minimum set point will increase. NOT AVAILABLE TYPES 820E, 822E, B122, E122, H122, H121K, H122K.

¹ All switches have limited DC capabilities. VDC ratings are not listed on nameplates. Consult factory for details.

² Deadbands change when switch options are added. Consult factory for details.

³ Not available for models 15622, 15834-15839, 15875, 13272, 13273, 13321 and 13322.



SWITCH OPTIONS** (CONT.)

1195	Hermetically sealed with gold flash contacts. DPDT. 11A 125/250 VAC resistive. 5A, 30 VDC; 1A, 48 VDC; 0.5A, 125 VDC resistive. Products set on falling pressure or temperature due to inherent separation of circuits on rising pressure or temperature. Specify option 1190 if setting on rise is required. Deadband and minimum set point will increase. NOT AVAILABLE TYPES 820E, 822E, B122, E122, H122, H121K, H122K.
1519*	Adjustable deadband. 15A, 125/250/480 VAC resistive. 0.5A, 125 VDC; 0.25A, 250 VDC resistive. Adjustable wheel changes rise setting only. If adjustment fall setting is required use primary adjustment. Deadband and minimum set point will increase. NOT AVAILABLE TYPES 820E, 822E, B121, E121, E122, H121, H122, H121K, H122K, OR MODELS 171-194, 483-494, 520-535, 565-567, 612-616.
1535	High ambient. 15A, 125/250/480 VAC resistive. 0.5A, 125 VDC; 0.25A, 250 VDC resistive. Temperatures up to 250°F (120°C). NOT AVAILABLE TYPES 820E, 822E, MODELS 520-535.
1537	Vapor sealed switch. 15A, 125/250 VAC resistive. NOT AVAILABLE TYPES 820E, 822E, OR MODELS 520-535.
1539	Fungus resistant case. 15A, 125/250 VAC resistive. 0.5A, 125 VDC; 0.25A, 250 VDC resistive. NOT AVAILABLE TYPES 820E, 822E, OR MODELS 520-535.
2000	20A, 125/250/480 VAC resistive. 0.5A, 125 VDC; 0.25A, 250 VDC resistive. NOT AVAILABLE MODELS 520-535, 540-548.
3000	30A, 125/250/277 VAC resistive. NOT AVAILABLE TYPES 820E, 822E, B121, B122, E122, H121, H122, H121K, H122K, J120K OR MODELS 171-194, 483-494, 520-535, 540-548, 565-567.

SENSOR OPTIONS

M504	316L stainless steel stem. AVAILABLE TEMPERATURE MODELS 120 AND 121 ONLY
M540	Viton® wetted parts with standard pressure connection. Deadbands and low end of range may increase. AVAILABLE MODELS 36-39, 450-454, 540-548. Models 455-457 (Viton® sealing diaphragms and O-rings with Teflon® main diaphragm). Models 612-616 (O-Ring only). AVAILABLE TYPE J120 MODELS 701-705 and TYPES H121 and H122 MODELS 701-703 with stainless steel pressure connection.
M913	1/4" NPT (female) stainless steel pressure connection. AVAILABLE ON MODELS S126B - S146B, S152B, S156B, S164B, 188 AND 189 ONLY
M914	1/2" NPT (female) stainless steel pressure connection. AVAILABLE ON MODELS 356, 358, 361, 376, 612 AND 616 ONLY
6361-762	1/2" NPT male to G1/2 male stainless steel pressure fitting adaptor kit
6361-761	1/4" NPT male to G1/2 male stainless steel pressure fitting adaptor kit

OPTIONAL SENSOR MATERIAL FOR "WC RANGES. AVAILABLE MODELS 520-525

XC001	Aluminum pressure connection, Viton® diaphragm, Viton® O-Ring
XC002	Aluminum pressure connection, Kapton® diaphragm, Buna N O-Ring
XC003	Aluminum pressure connection, Kapton® diaphragm, Viton® O-Ring
XC004	316L Stainless steel pressure connection, 316L Stainless steel diaphragm, Viton® O-Ring (Over range pressure is limited to 100 psi)
XC005	316L Stainless steel pressure connection, Viton® diaphragm, Viton® O-Ring
XC007	316L Stainless steel pressure connection, Teflon® diaphragm, Viton® O-Ring

OPTIONAL SENSOR MATERIAL FOR CORROSIVE MEDIA. AVAILABLE MODELS 183-189, 483-489

XD002	Hastelloy® C 276 diaphragm (NACE MR-0175 compliant)
XD003	Monel® 400 diaphragm (NACE MR-0175 compliant)

*Please note: In order to accommodate free movement of adjustable wheel, left hand electrical conduit is permanently sealed.

** All switches have limited DC capabilities and are based on experience. VDC ratings are not listed on nameplates. Consult factory for details.

OPTIONAL SENSOR MATERIAL FOR CORROSIVE MEDIA (CONT.)

XP112	Hastelloy® C 276 pressure connection (NACE MR-0175 compliant)
XP113	Monel® 400 pressure connection (NACE MR-0175 compliant)
XR211	Kalrez® O-Ring
XR213	Ethylene propylene O-Ring
XR214	Aflas® O-Ring

OTHER OPTIONS

M201	Factory set one switch
M202	Factory set two switches. NOT AVAILABLE SINGLE SWITCH VERSIONS
M210	Differential pressure indication. AVAILABLE ON H121K, H122K, MODELS 147, 157, S147B, S157B ONLY
M277	Range indicated on nameplate in kPa or MPa. NOT AVAILABLE ON TEMPERATURE VERSIONS
M278	Range indicated on nameplate in Kg/cm ² . NOT AVAILABLE ON TEMPERATURE VERSIONS
M320	Tamper resistant cover for indication portion of control, internal adjustment. AVAILABLE TYPES 820E AND 822E ONLY
M391	Flame proof, intrinsic safety for INMETRO compliance.
M395	Flame proof compliance Ex d per Korea Occupational Safety and Health Agency (KOSHA)
M404	Flameproof compliance for Ukraine per Gosnadzorohrantruda permits.
M405	Intrinsic safety compliance for European Union per ATEX standards. NOT AVAILABLE TYPES 820E AND 822E
M406	Flameproof and intrinsic safety compliance for Russia per EAC permit. Intrinsic safety NOT AVAILABLE TYPES 820E & 822E
M408	Flameproof compliance for China per CQST standards
M440	Cover chain
M444	Paper ID tag
M446	Stainless steel ID tag & wire attachment; limited to 2 lines of 25 characters each max.
M449	Surface mounting hardware kit that is required for models 520-535 & 540-548 when surface mounting. Use option code only at time of ordering product, otherwise use surface and pipe mounting kit part number 6361-704 as a separate order or for other models.
M550	Oxygen service cleaned in accordance with ASTM G93, Verification Type I, Tests 1 through 3. NOT AVAILABLE on H122, or MODELS 455-457, 559, 704 and 705
6361-704	Surface and pipe mounting hardware kit for all models. Required for surface mounting models 520-535 & 540-548 if not previously ordered with option M449.

NOTE: Options available on models 13272, 13273, 13321, 13322, 15622, 15834-15839 and 15875 are M201, M202, M444, M446 and various certification related documentation only.



OPTIONS FOR TEMPERATURE MODELS

UNION CONNECTORS

Option	Replacement Number	Description
	<u>Brass</u>	
W027	SD6213-27	1/2" NPT w/ 3/4" bushing
W045	SD6213-45	3/4" NPT
W051	SD6213-51	1/2" NPT
	<u>304 Stainless Steel</u>	
W028	SD6213-28	1/2" NPT w/ 3/4" bushing
W046	SD6213-46	3/4" NPT
W050	SD6213-50	1/2" NPT

THERMOWELLS

For all bulb & capillary switches, except Models 13273 and 13321

	<u>Brass</u>	
W075	SD6225-75	3/4" NPT bushing adapter, 4" BT
W191	SD6225-191	1/2" NPT, 4" BT
W118	SD6225-118	3/4" NPT bushing adapter, 7" BT
W192	SD6225-192	1/2" NPT, 7" BT
	<u>316 Stainless Steel</u>	
W076	SD6225-76	3/4" NPT, 4.5" BT
W193	SD6225-193	1/2" NPT, 4.5" BT
W119	SD6225-119	3/4" NPT, 7.5" BT
W177	SD6225-177	1/2" NPT, 7.5" BT

For all immersion stem switches, except Models 13272 and 13322

W139	SD6225-139	3/4" NPT X 1-23/32" BT, BRASS
W140	SD6225-140	3/4" NPT X 1-23/32" BT, 316 ST/ST

W000 IMMERSION STEM AND THERMOWELLS

Note: Option W000 is a special Immersion Stem construction that has no external thread. This option fits inside a special thermowell and is secured with a set-screw.

Option	Description
W000	Immersion stem only, BRASS
W097	Immersion stem and thermowell. Includes W000 stem and 1/2" NPT x 1-23/32" BT BRASS thermowell
W099	Immersion stem and thermowell. Includes W000 stem and 1/2" NPT x 1-23/32" BT 316 ST/ST thermowell

OPTIONAL LENGTHS

Optional immersion stem lengths to 15" may be available in brass, with or without 316 ST/ST thermowell. Consult UE for availability.

Optional capillary length to *50' may be available in copper or 304 ST/ST. Consult UE for availability. Armor or Teflon® capillary protection may be available to lengths less than or equal to capillary length. Consult UE for availability.

*Consult UE regarding repeatability and ambient effects on capillary lengths over 30'.

DIMENSIONAL DRAWINGS

(Dimensional drawings for all models may be found at www.ueonline.com)

Internal Set Point Adjustment, dual conduits

Types J120, J120K, C120, F120

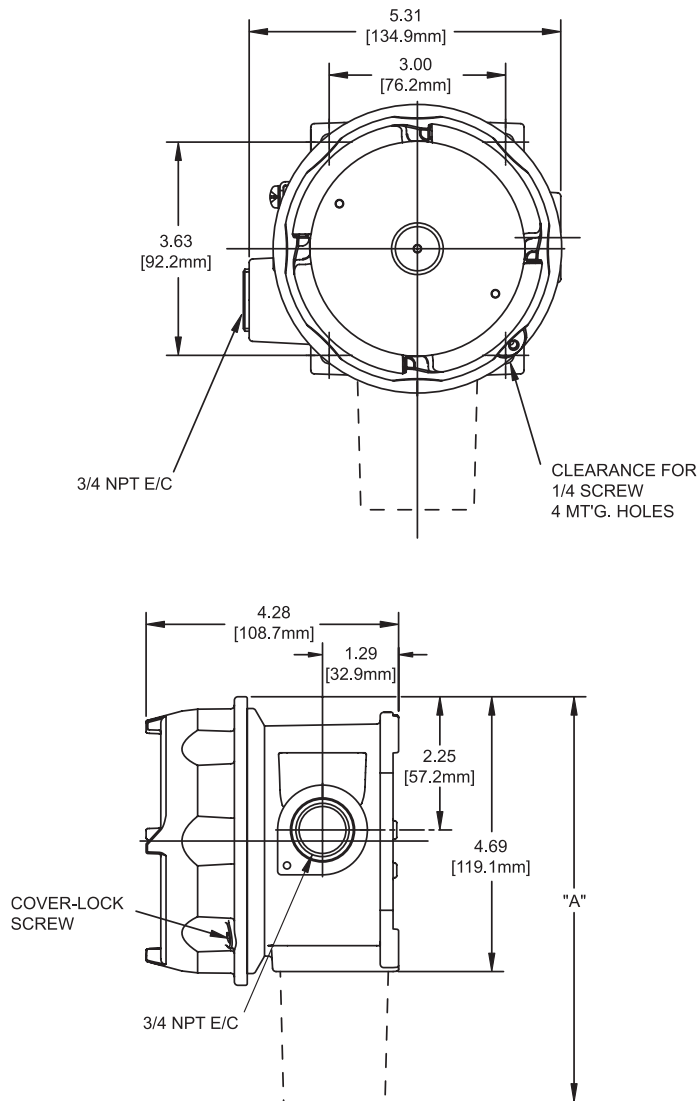

All dimensions stated in inches (millimeters)

Models	Dimension A		
	Inches	mm	NPT
Pressure			
126-164	7.25	184.2	1/4
S126B-S164B	7.63	193.8	1/2
171-174	8.72	221.5	1/2
183-186, 483-486	8.41	213.6	1/2
188-189, 488-489	7.47	189.7	1/2
190-194, 490-494	7.44	189.0	1/2
270-274	8.13	206.5	1/4
356-361, 376	8.09	205.5	1/4
450, 452	8.81	223.8	1/4
451, 453, 454	8.06	204.7	1/4
520-525	9.25	235.0	1/2
530-535	8.84	224.5	1/2
550, 552	8.81	223.8	1/4
551, 553-555	8.34	211.8	1/4
565-567	7.53	191.3	1-1/2" Sanitary
612, 616	7.88	200.2	1/4
680	8.13	206.5	1/4
701-705, 15622	7.44	189.0	1/4
Differential Pressure			
36-39, 147-157, 367	7.59	192.8	1/4
S147B-S157B	7.59	192.8	1/2
455-457, 559	8.44	214.4	1/4
540-543	9.34	237.2	1/8
544-548	9.41	239.0	1/8
Temperature			
120-121	9.13	231.9	Immersion Stem
2B5-8B5	8.47	215.1	Bulb & capillary

DIMENSIONAL DRAWINGS

(Dimensional drawings for all models may be found at www.ueonline.com)

External Set Point Adjustment, single conduit

Types B121, B122, E121,
E122, H121, H122, H121K, H122K

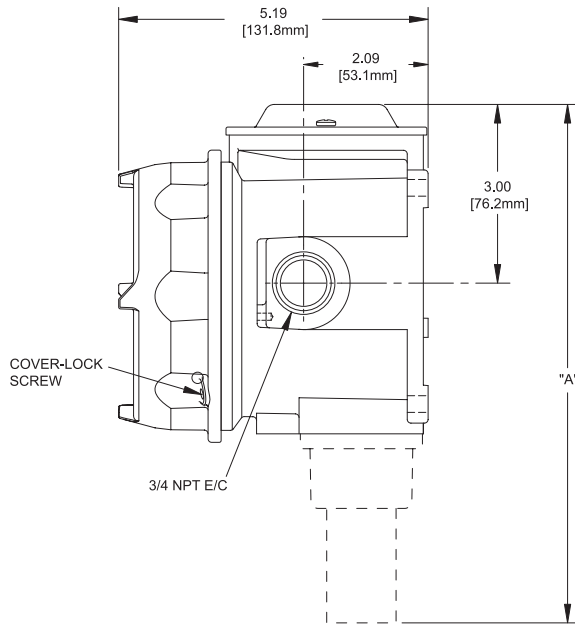
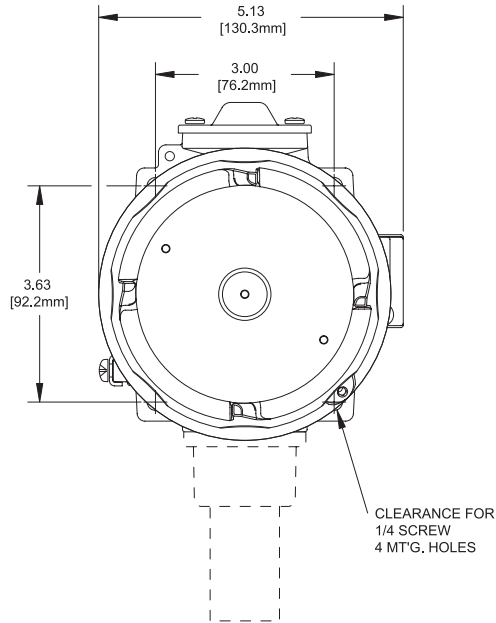

Models	Dimension A		NPT
	Inches	mm	
Pressure			
126-164	8.09	205.5	1/4
5126B-5164B	8.50	215.9	1/2
270-274	7.88	200.2	1/4
358-376	7.81	198.4	1/4
450, 452	9.69	246.1	1/4
453, 454	8.94	227.1	1/4
550, 552	9.75	247.7	1/4
553-555	9.31	236.5	1/4
612, 614	8.75	222.3	1/4
701-705	8.31	211.1	1/4
Differential Pressure			
147-157	8.44	214.4	1/4
5147B-5157B	8.44	214.4	1/2
456-457, 559	9.31	236.5	1/4
Temperature			
120,121	10.00	254.0	Immersion Stem
285-885	9.31	236.5	Bulb & capillary
13272, 13322	10.00	254.0	Immersion Stem (Heat tracing)
13273, 13321	9.31	236.5	Bulb & capillary (Heat tracing)

DIMENSIONAL DRAWINGS

(Dimensional drawings for all models may be found at www.ueonline.com)

External Set Point Adjustment & Temperature Indication

Type 820E
single switch

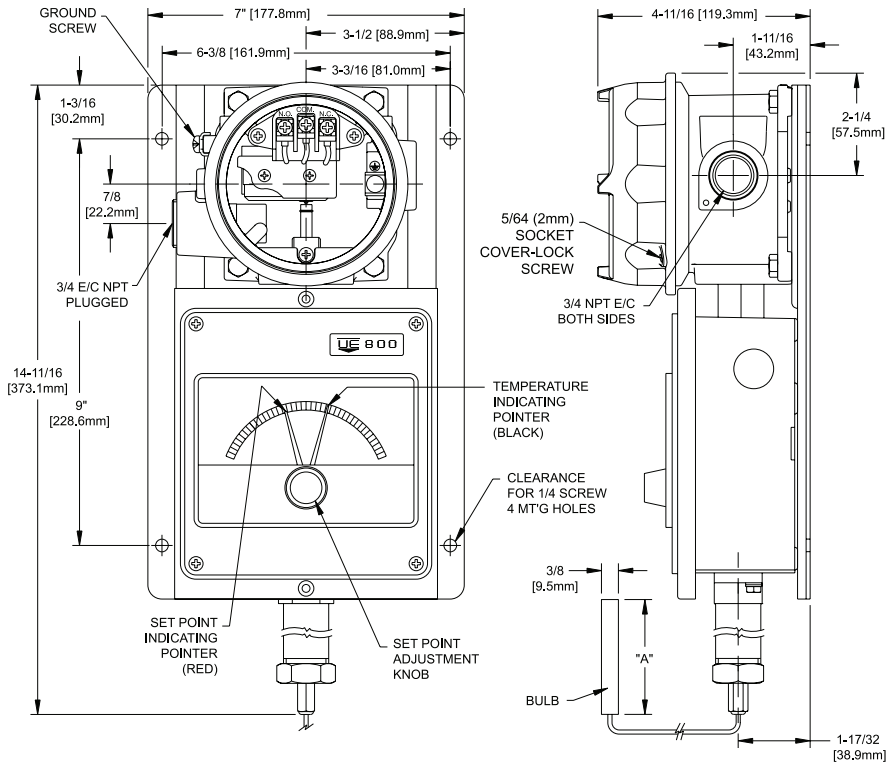

Models	Dimension A	
	Inches	mm
2BS	2-5/8	66.7
3BS	2-1/8	54.0
4BS	6-3/4	171.5
5BS	5	127.0
6BS	4-1/2	114.3
7BS	3	76.2
8BS	3-1/4	82.6

Type 822E
dual switch

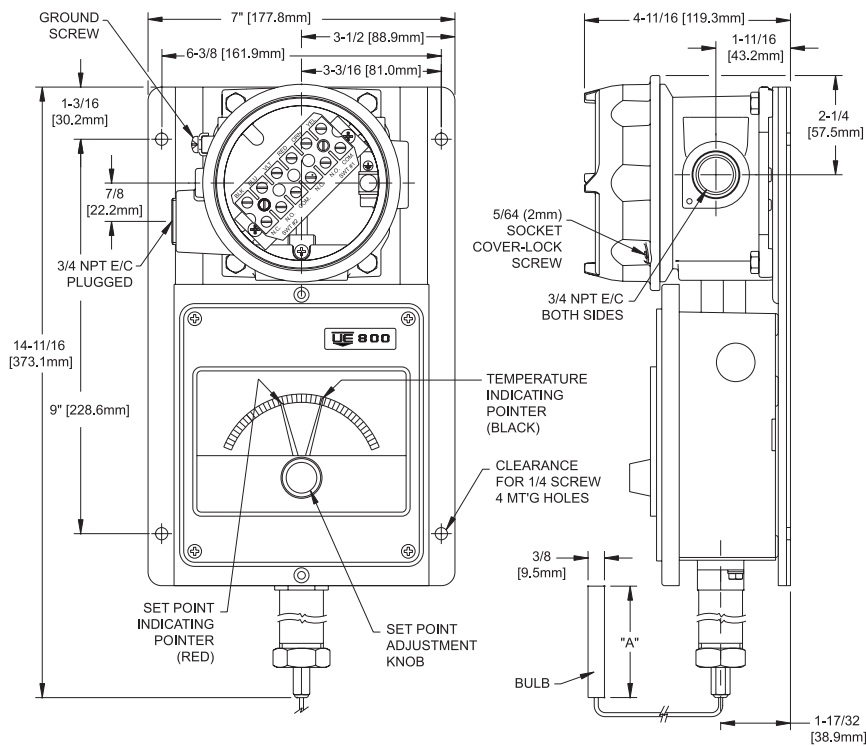

DIMENSIONAL DRAWINGS

SENSORS

Pressure Sensors

(see drawings and charts on page 21 & 22 for complete dimensions)

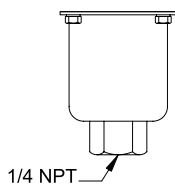

Models 126-164

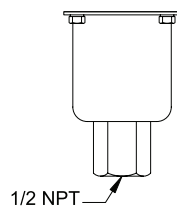

Models S126B-S164B

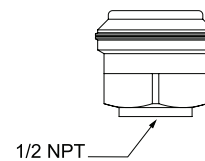

Models 171-174

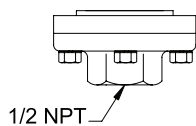

Models 183-186, 483-486

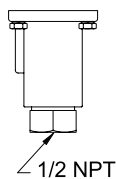

Models 188-194, 488-494

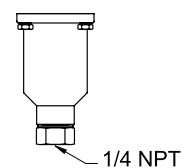

J120 Models 270-376, 680

DIMENSIONAL DRAWINGS

SENSORS

Pressure Sensors

(see drawings and charts on page 21 & 22 for complete dimensions)

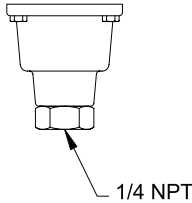

H121/H122 Models 270-376

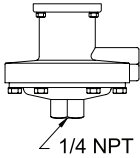

Models 450-454, 550-555

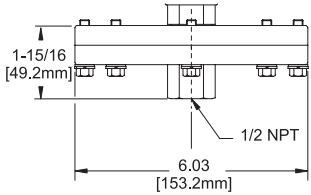

Models 520-525

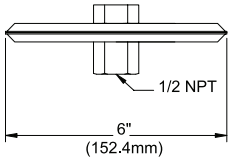

Models 530-535

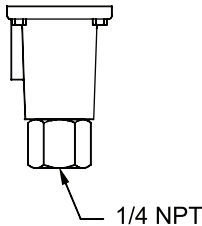

Models 612-616, 701-705, 15622

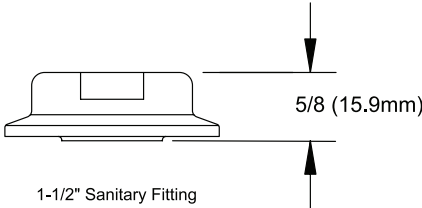

Models 565-567

DIMENSIONAL DRAWINGS

SENSORS

Differential Pressure Sensors

(see drawings and charts on page 21 & 22 for complete dimensions)

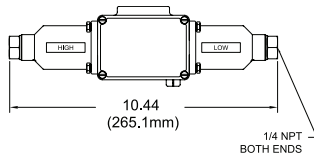

J120K Models 367

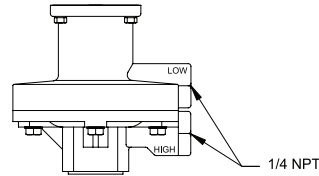

Models 455-457, 559

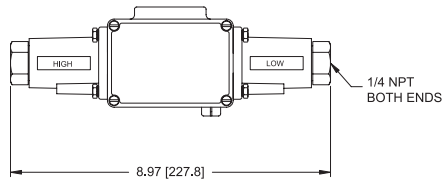

J120K Models 36-39

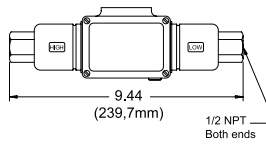

Models S147B-S157B

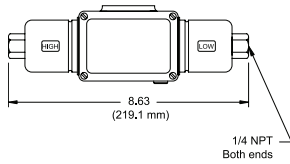

Models 147-157

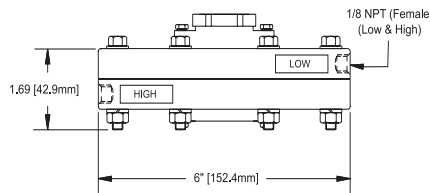

Models 540-543

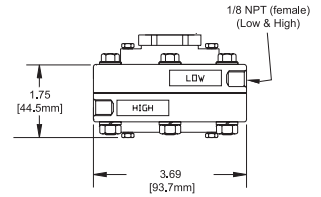

Models 544-548

Temperature Sensors

(See drawings and charts on pages 21-23 for complete dimensions, as well as Temperature Model Chart on pages 15-16 for immersion stem and bulb dimensions. The standard capillary length is 6 feet except for models 13273 & 13321 which is 10 feet)

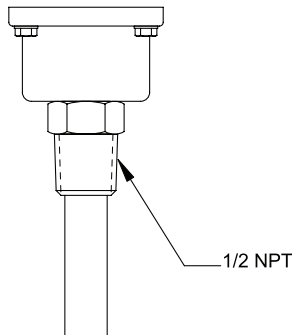

Models

120-121, 13272*, 13322*

*Please Note: These models do not include the 1/2 NPT

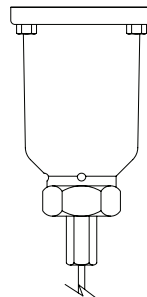

Models

2B5-8B5, 13273, 13321

ALTERNATIVE PRODUCTS FROM UE

One Series Safety Transmitter for Division 1 (Zone 1)

- Improve Uptime with safety diagnostics
- Capable of switching the final element directly
- Meet regulatory requirements with SIL2 IEC 61508 certification
- Simplify complex safety systems with SFF = 98.8
- Reduce migration costs with backward and forward compatibility

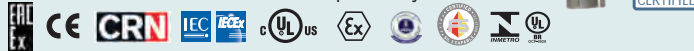

TX200 Series HART® & ASIC Pressure Transmitter

- Smart TX200H offers HART 7 communication and 4-20 mA output
- TX200H 10:1 range turndown helps reduce inventory
- ASIC based TX200 offers 4-20 mA output or 1-5 VDC or 0-10 VDC output
- Rugged 316 stainless steel construction, welded and hermetically sealed
- Wide variety of process connections available for pressure ranges from 0 to 15 psi up to 0 to 25,000 psi



Stainless Steel 12 Series

- Compact, cylindrical 316 stainless steel design
- Hermetically sealed micro-switch
- Explosion Proof
- Snap-acting bellville spring mechanism for maximum vibration resistance and set point stability
- Pressure ranges 1 to 12,500 psi; DP working pressure ranges 0 to 2500 psid; temperature ranges -130 to 650°F
- Dual seal compliance to ANSI/ISA 12.27.01



One Series for Division 1 & 2 (Zone 0, 1, 2)

- Easy and secure programming via local keypad or read-only remote HART® 7 communications
- Money-saving drop-in replacement for mechanical switches using the 2-wire switch-only version
- Achieve high reliability through IAW™ self-diagnostics and separate alarm contact
- Gain Asset Management data through HART 7 reporting
- A complete, flexible solution – 4-20mA for trending plus 2 relays for local switching - all accessible via HART® 7 Communications Protocol



Temperature Sensors

Rugged RTD's and Thermocouples for process and energy applications, available with Nema 4X and explosion-proof heads to match heat-trace, turbine, combustion, and stack-emission applications



RECOMMENDED PRACTICES AND WARNINGS

United Electric Controls Company recommends careful consideration of the following factors when specifying and installing UE pressure and temperature units. Before installing a unit, the Installation and Maintenance instructions provided with unit must be read and understood.

- To avoid damaging unit, proof pressure and maximum temperature limits stated in literature and on nameplates must never be exceeded, even by surges in the system. Operation of the unit up to maximum pressure or temperature is acceptable on a limited basis (e.g., start-up, testing) but continuous operation must be restricted to the designated adjustable range. Excessive cycling at maximum pressure or temperature limits could reduce sensor life.
- A back-up unit is necessary for applications where damage to a primary unit could endanger life, limb or property. A high or low limit switch is necessary for applications where a dangerous runaway condition could result.
- The adjustable range must be selected so that incorrect, inadvertent or malicious setting at any range point cannot result in an unsafe system condition.
- Install unit where shock, vibration and ambient temperature fluctuations will not damage unit or affect operation. When applicable, orient unit so that moisture does not enter the enclosure via the electrical connection. When appropriate, this entry point should be sealed to prevent moisture entry.
- Unit must not be altered or modified after shipment. Consult UE if modification is necessary.
- Monitor operation to observe warning signs of possible damage to unit, such as drift in set point or faulty display. Check unit immediately.
- Preventative maintenance and periodic testing is necessary for critical applications where damage could endanger property or personnel.
- Electrical ratings stated in literature and on nameplate must not be exceeded. Overload on a switch can cause damage, even on the first cycle. Wire unit according to local and national electrical codes, using wire size recommended in installation sheet.
- Do not mount unit in ambient temp. exceeding published limits.

LIMITED WARRANTY

Seller warrants that the product hereby purchased is, upon delivery, free from defects in material and workmanship and that any such product which is found to be defective in such workmanship or material will be repaired or replaced by Seller (Ex-works, Factory, Watertown, Massachusetts. INCOTERMS); provided, however, that this warranty applies only to equipment found to be so defective within a period of 24 months from the date of manufacture by the Seller. Seller shall not be obligated under this warranty for alleged defects which examination discloses are due to tampering, misuse, neglect, improper storage, and in any case where products are disassembled by anyone other than authorized Seller's representatives. EXCEPT FOR THE LIMITED WARRANTY OF REPAIR AND REPLACEMENT STATED ABOVE, SELLER DISCLAIMS ALL WARRANTIES WHATSOEVER WITH RESPECT TO THE PRODUCT, INCLUDING ALL IMPLIED WARRANTIES OF MERCHANTABILITY OR FITNESS FOR ANY PARTICULAR PURPOSE.

LIMITATION OF SELLER'S LIABILITY

SELLER'S LIABILITY TO BUYER FOR ANY LOSS OR CLAIM, INCLUDING LIABILITY INCURRED IN CONNECTION WITH (I) BREACH OF ANY WARRANTY WHATSOEVER, EXPRESSED OR IMPLIED, (II) A BREACH OF CONTRACT, (III) A NEGLIGENT ACT OR ACTS (OR NEGLIGENT FAILURE TO ACT) COMMITTED BY SELLER, OR (IV) AN ACT FOR WHICH STRICT LIABILITY WILL BE INPUTTED TO SELLER, IS LIMITED TO THE "LIMITED WARRANTY" OF REPAIR AND/OR REPLACEMENT AS SO STATED IN OUR WARRANTY OF PRODUCT. IN NO EVENT SHALL THE SELLER BE LIABLE FOR ANY SPECIAL, INDIRECT, CONSEQUENTIAL OR OTHER DAMAGES OF A LIKE GENERAL NATURE, INCLUDING, WITHOUT LIMITATION, LOSS OF PROFITS OR PRODUCTION, OR LOSS OR EXPENSES OF ANY NATURE INCURRED BY THE BUYER OR ANY THIRD PARTY.

UE specifications subject to change without notice.

FOR A LIST OF OUR INTERNATIONAL AND DOMESTIC
REGIONAL SALES OFFICES PLEASE VISIT OUR
WEBPAGE WWW.UEONLINE.COM



UNITED ELECTRIC
CONTROLS
180 Dexter Avenue, P.O. Box 9143
Watertown, MA 02471-9143 USA
Telephone: 617 926-1000 Fax: 617 926-2568
www.ueonline.com