

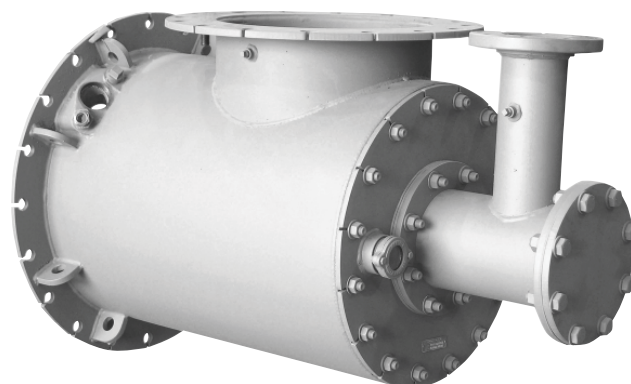

- **Gas-only Burner**
- **Short and wide flame pattern**
- **18 to 75 million Btu/hr**
- **For furnaces, boilers, air heaters, incinerators, gypsum kettles, etc.**
- **Broad Stability Range**
- **Chambers up to 2200F**



4796 Magna-Flame™ Gas Burners are designed to fire combustion chambers that have a limited length but with sufficient width to allow the flame envelope to develop. The burner is particularly well suited to cubic combustion chambers typical of coal-fired water tube boilers.

Operation is quiet and the flame is tile-stable. Although the burner was not specifically designed to operate with excess air, it is stable from rich air/fuel ratios up to 150% excess air. It can be used in cold, sealed-in combustion chambers.

Available sizes from 12" through 24" permit use of a single burner in place of multiple burners otherwise often required to obtain a desired input in a chamber of limited length.

The 4796 Magna-Flame burner produces about 10% lower NOx emissions than conventional gas burners. The same high swirl that creates a short bushy flame also pulls furnace gases into the flame's primary reaction zone to reduce NOx formation.

CONSTRUCTION. The body is fabricated of heavy duty welded steel with a refractory ring and alloy air spin vane in the front. Connections for pilot and flame detector can be factory-installed in any of several locations per customer specification. See Dimensions page 2.

PILOT and FLAME SUPERVISION. Magna-Flame burners should be pilot ignited[Ⓛ]. The 4014 gas-boosted pilot (sold separately) listed in the dimension table is required, and provision must be made for low fire start with 1.0"wc or less main air. The pilot must be of the interrupted type to prevent overheating of the mounting. The UV detector location should be 90° clockwise of the pilot when viewing rear of burner (in the direction of air swirl). Self-checking UV scanners (sold separately) are recommended for flame supervision. See Bulletin 8832 for selection of UV adapters. It is possible for a UV scanner mounted on this burner to sight flame(s) of other burners in the same firing chamber. Consult Fives North American for configuration guidance on multiple burner applications.

CONTROL. Mass flow control systems are normally used with 4796 Burners, at least in the larger sizes. Cross-connected regulator systems can also be used because the required gas pressure is approximately 0.6 times the air pressure.

INSTALLATION. The burner does not include a refractory tile. The shape shown on the dimension drawing (page 2) must be built into the combustion chamber wall. See Supplement DF-M1 for installation recommendations.

Burner Designation	Combustion Air Capacities (scfh) Multiply by 100 to get Btu per hour Air pressure drop across the burner, osi				Maximum % Excess Air Air pressure in osi			Flame Dimensions @ 8 osi main air and 10% XSair	
	1.0	5.0	6.0	8.0 [Ⓜ]	0.2	4.0	8.0	Length	Diameter
4796-12	67 000	150 000	164 000	190 000	500	200	150	6'	5'
4796-14	86 000	193 000	211 000	244 000	500	200	150	7'	6'
4796-16	120 000	269 000	295 000	340 000	500	200	150	7½'	6'
4796-18	155 000	346 000	380 000	438 000	500	200	150	8'	6'
4796-20	200 000	447 000	490 000	565 000	500	200	150	9'	7'
4796-22	237 000	530 000	580 000	670 000	500	200	150	9½'	8'
4796-24	282 000	630 000	690 000	795 000	500	200	150	10'	8'

[Ⓛ] Because of a positive pressure in the burner, it is difficult to light with a torch unless the air is turned very low and a strong pressure torch is used.
[Ⓜ] Maximum recommended pressure.

WARNING: Situations dangerous to personnel and property may exist with the operation and maintenance of any combustion equipment. The presence of fuels, oxidants, hot and cold combustion products, hot surfaces, electrical power in control and ignition circuits, etc., are inherent with any combustion application. Parts of this product may exceed 160F in operation and present a contact hazard. Fives North American Combustion, Inc. urges compliance with National Safety Standards and insurance Underwriters recommendations, and care in operation.

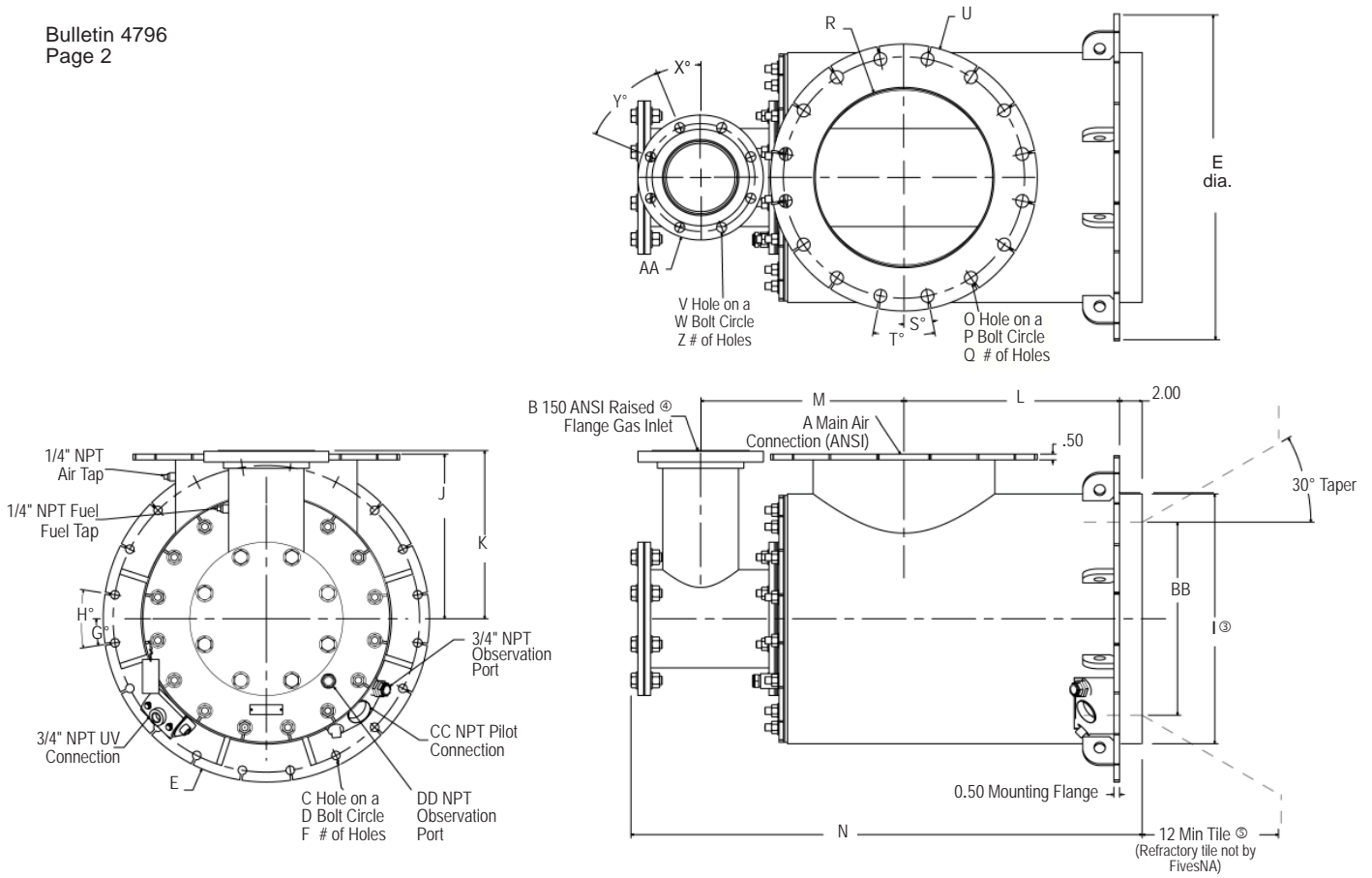

DIMENSIONS SHOWN ARE SUBJECT TO CHANGE. PLEASE OBTAIN CERTIFIED PRINTS FROM FIVES NORTH AMERICAN COMBUSTION, INC. IF SPACE LIMITATIONS OR OTHER CONSIDERATIONS MAKE EXACT DIMENSION(S) CRITICAL.

Dimensions in inches and degrees

Burner Designation	A	B	C	D	E	F	G°	H°	I [Ⓢ]	J	K	L	M	N	O	P	Q	R
4796-12	12	4	0.75	24.25	26	16	11.25	22.5	18	12.5	14.75	15	14.44	36.75	1	17	12	12.25
4796-14	14	6	0.75	25.25	27	16	11.25	22.5	20	13.5	14.81	18	17.38	43.38	1.13	18.75	12	13.88
4796-16	16	6	0.75	27	28.75	20	9	18	22	14.5	14.81	19	18.38	45	1.13	21.25	16	15.88
4796-18	18	6	0.75	29	30.75	20	9	18	24	15.5	14.81	19.5	18.88	45.88	1.25	22.75	16	17.88
4796-20	20	8	0.88	31	32.75	20	9	18	26	16.5	14	19.63	21.13	50	1.25	25	20	19.88
4796-22	22	8	0.88	33.5	35.25	20	9	18	28	17.5	14	21	21.88	52.13	1.25	26	20	21.88
4796-24	24	8	0.88	35.5	37.75	24	7.5	15	30	18.5	14	22	24.38	56.13	1.38	29.5	20	23.88

Burner Designation	S°	T°	U	V	W	X°	Y°	Z	AA	BB	CC	DD	Recom- mended Pilot Designation	Wt. lbs.
4796-12	15	30	19	0.75	7.5	22.5	45	8	9	12.5	1.5	¼	4014-2-T	325
4796-14	15	30	21	0.88	9.5	22.5	45	8	11	14.75	2	¼	4014-3-AT	430
4796-16	11.25	22.5	23.5	0.88	9.5	22.5	45	8	11	17	2	¼	4014-3-AT	480
4796-18	11.25	22.5	25	0.88	9.5	22.5	45	8	11	19.25	2	2	4014-3-AT	530
4796-20	9	18	27.5	0.88	11.75	22.5	45	8	13.5	21.5	2	2	4014-3-BT	620
4796-22	9	18	29.5	0.88	11.75	22.5	45	8	13.5	24	2	2	4014-3-BT	675
4796-24	9	18	32	0.88	11.75	22.5	45	8	13.5	26	2	2	4014-3-BT	745

- Ⓢ Furnace opening should be 1/2" larger than dimension I for sizes -12 through -16 and 3/4" larger than dimension I for sizes -18 through -24.
- Ⓢ Flat face ANSI flange available upon request.
- Ⓢ For tiles longer than 15" consult Fives North American Combustion.

Arrangement Designators are specified relative to the main air connection at 12 o'clock and should be listed for **pilot, gas connection, and flame detector in that order.**

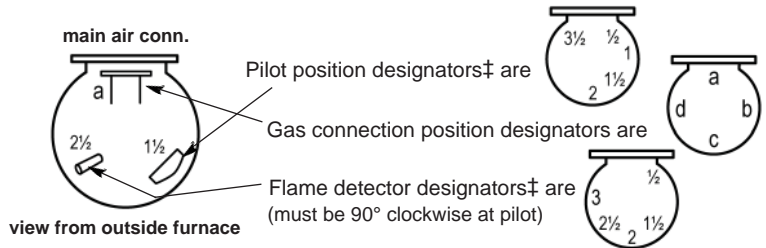

± Good practice dictates that neither pilot nor flame detector be below the centerline of a horizontally-mounted burner.

ORDER MUST SPECIFY: (1) Burner designation (such as 4796-16): (2) Arrangement designation for pilot, gas connection and flame safety positions in that order such as: 4796-16, arrangement 1 1/2 a 2 1/2 (for the arrangement shown above).

Fives North American Combustion, Inc. - 4455 East 71st Street - Cleveland, OH 44105 USA - Phone 216.271.6000

Fax 216.641.7852 - email: fna.sales@fivesgroup.com - www.fivesgroup.com/fivesna