

MAXON M-PAKT®
Ultra Low NOx Burners

Honeywell



Technical Catalog

TABLE OF CONTENTS

Product description	1
Features and benefits	1
Typical emissions	1
Model Numbers	2
Specifications of M-PAKT® Burners	3
Materials of construction	4
Selection criteria	4
Dimensions.....	6
0.4M & 0.9M Packaged Burners - gas control method "S"	6
1.5M, 2.5M and 3.0M Packaged Burners - gas control method "S"	7
EB2 and EB3 (External Blower) Burners - gas control method "S"	8
EB4, EB5, & EB6 (External Blower) Burners - gas control method "S"	9
EB7 (External Blower) Burners - gas control method "S"	10
Alternate gas control methods - gas control method "C"	11
Accessories and options	12
Installation and Operating Instructions for M-PAKT® Burners	13
Application Requirements	13
Installation Instructions	13
Start-up Instructions for M-PAKT® Burner	14
Fuel/Air Relationships - Packaged M-PAKT® Burner	16
Fuel/Air Relationships - EB M-PAKT® Burner	16
Maintenance and Inspection Instructions	17

PRODUCT DESCRIPTION

Typical MAXON quality and reliability is found in the M-PAKT® Ultra Low NOx Burners, which provide the world's lowest levels of NOx and CO. NOx is typically single digits in most applications. The M-PAKT® low NOx burner is suitable for industrial air heating for ovens and dryers for paint finishing, paper making, food baking, textile production, grain drying, and make-up air heating. M-PAKT® burners substantially reduce emissions in oxidizers, incinerators, heat exchangers and process heaters.

FEATURES AND BENEFITS

- Produces extremely low emissions of NO_x and CO
- Burns natural gas or propane
- Flame contained almost entirely inside the discharge sleeve
- Compact packaged design with a variety of control methods
- Durable steel outer construction with stainless steel internals

TYPICAL EMISSIONS

The M-PAKT® Ultra Low Emissions Burner produces NOx and CO emissions up to 95% less than conventional burners. Without exotic alloys or fragile ceramics, the burner reduces NOx with a patented, advanced flame stabilization. The M-PAKT® burner's advanced anchoring of the flame reduces prompt NOx while thermal NOx is suppressed with an extremely uniform mixture.

In application, the M-PAKT® Ultra Low Emissions Burner produces single digit NOx corrected to 3% oxygen. In most installations, CO production is limited to extremely low levels. Exact emissions performance may vary in your application. Contact MAXON for information on installation specific estimates or guarantees. No guarantee of emissions is intended or implied without specific written guarantee from MAXON.

Factors that can affect emissions:

- Process air direction, temperature and velocity
- Process stream constituents, especially nitrogen bearing compounds
- Combustion air quality, relative humidity and filtration
- Burner location and installation
- Fuel quality and heating value
- Emissions instrument calibration and testing protocol

APPLICATION EXAMPLE OF M-PAKT® GAS BURNER

- 1) M-PAKT® Ultra Low NOx Burner
- 2) Pipe train constructed for required codes and authorities
- 3) MAXON Shut-off Valves
- 4) Combustion air blower
- 5) System control panel

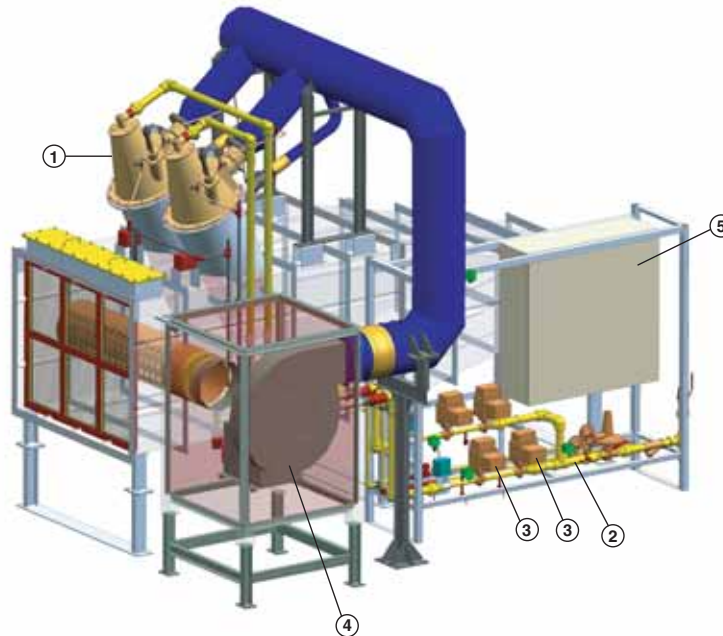

A typical air heater incorporating M-PAKT burners

MODEL NUMBERS

A coded model number is provided on the nameplate of all M-PAKT® Burners to provide an instantaneous method to identify the configuration of the product. This model number ensures accuracy in identifying your product, ordering replacement parts or communicating capabilities.

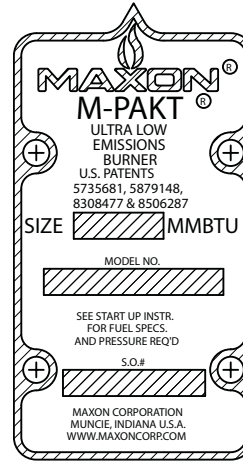

Special (S if special, blank if not)	Burner type	Size	Blower	Discharge sleeve	Mechanical gas control	Switches	Filter/silencer	Future options
S	MPB	1	1	R	S	F	N	AAA

Burner type

MPB - M-PAKT® burner

Size

- 1 - 0.4M
- 2 - 0.9M
- 3 - 1.5M
- 4 - 2.5M
- 5 - 3.0M
- A - EB2
- B - EB3
- C - EB4
- D - EB5
- E - EB6
- F - EB7

Blower

- 1 - 240/3/50
- 2 - 575/3/60
- 3 - 110/1/60
- 4 - None

Discharge sleeve

R - RA330 stainless steel

Mechanical gas control

- C - Honeywell ControlLinks
- S - SMARTLINK MRV
- E - External control (EB only)

Switches

F - None

Filter/silencer

- F - Filter only
- S - Filter/silencer
- N - None

SPECIFICATIONS OF M-PAKT® BURNERS

Typical burner data						
Fuel: natural gas at 60°F with 1000 Btu/ft ³ (st) HHV - sg = 0.6 [1]						
Combustion air: 60°F - 21% O ₂ - 50% humidity - sg = 1.0 [1]						
Stated pressures are indicative. Actual pressures are a function of air humidity, altitude, type of fuel and gas quality.						
Packaged Burners						
Size		0.4M	0.9M	1.5M	2.5M	3.0M
Maximum Capacity HHV [4]	MBtu/h	0.41	0.9	1.6	2.5	3.0
Minimum Capacity HHV		0.07	0.128	0.2	0.37	0.5
Turndown	N/A	5.9:1	7:1	8.5:1	7:1	7.4:1
Pilot Capacity	KBtu/h	20-80	20-80	20-80	20-80	20-80
Natural Gas Pressure [3]	"wc	4.1	10.4	8.6	10.3	9.5
Inlet Gas Pressure	"wc	8	25.5	19	37	33
Combustion Air Pressure [5] [6]	"wc	8.8	8.8	10.1	10.4	9.4
Combustion Air Flow	scfm	116	255	453	708	992
Fan Horsepower	hp	1.5	1.5	2	3	3
Burner Sound Levels [2]	dB(A)	86.1	86.3	87.2	89.3	89.5
With Silencer		82.0	82.2	84.0	82.0	82.0

- [1] sg (specific gravity) = relative density to air (density air = 0.0763 lb/ft³ (st))
 - [2] Sound pressure level, Lp, measured at 39 inches from the burner
 - [3] Gas pressure measured differentially at burner gas pressure test connection.
 - [4] Capacity displayed assumes blower operation on 60Hz electrical supply. Gross output will be reduced by 17% if operated on 50Hz. Fuel and air pressures should be reduced by 30% while motorpower will reduce 40% with 50Hz operation.
 - [5] Air differential pressure measured between chamber pressure test port and burner air test connection.
 - [6] Allow at least 10% more pressure at air valve inlet.
- Contact MAXON for operating pressures for burners produced prior to May 2007.

Typical burner data							
Fuel: natural gas at 60°F with 1000 Btu/ft ³ (st) HHV - sg = 0.6 [1]							
Combustion air: 60°F - 21% O ₂ - 50% humidity - sg = 1.0 [1]							
Stated pressures are indicative. Actual pressures are a function of air humidity, altitude, type of fuel and gas quality.							
External Blower Burners							
Size		EB2	EB3	EB4	EB5	EB6	EB7
Maximum Capacity HHV [5]	MBtu/h	0.8	1.7	2.7	4.5	5.8	8.4
Minimum Capacity HHV		0.07	0.128	0.2	0.37	0.5	0.9
Turndown	N/A	11.4:1	13.3:1	13.5:1	12.2:1	11.6:1	9.1:1
Pilot Capacity	KBtu/h	20-80	20-80	20-80	20-80	20-80	20-80
Natural Gas Pressure [2] [3]	"wc	12.1	37.2	24	32.6	37	60
Inlet Gas Pressure	"wc	14.8	48.5	34.8	63	45.8	78
Combustion Air Pressure [4] [6]	"wc	29.4	29.7	28	32.9	27.5	27.2
Combustion Air Flow	scfm	227	482	765	1275	1643	2380

- [1] sg (specific gravity) = relative density to air (density air = 0.0763 lb/ft³ (st))
 - [2] Gas pressure measured differentially at burner gas pressure test connection.
 - [3] Gas differential pressure required at burner inlet when using control method 'E'
 - [4] Air differential pressure measured between chamber pressure test port and burner air test connection
 - [5] Capacity displayed assumes blower operation on 60Hz electrical supply. Gross output will be reduced by 17% if operated on 50Hz. Fuel and air pressures should be reduced by 30% while motorpower will reduce 40% with 50Hz operation.
 - [6] Allow at least 10% more pressure at air valve inlet.
- Contact MAXON for operating pressures for burners produced prior to May 2007.

MATERIALS OF CONSTRUCTION

The M-PAKT Ultra Low NOx burner is constructed from durable, industrial steel and stainless steel components.

Burner Part	Material
Housing	1010 steel
Gas nozzle	304 stainless steel (1.4301)
Cone	330 stainless steel (1.4333)
Discharge sleeve	330 stainless steel (1.4333)
Impeller	Aluminum
Fan case	Steel

SELECTION CRITERIA

M-PAKT® BURNER VERSIONS

M-PAKT® Ultra Low NOx Burners are available as packaged burners with integral blower and fuel/air ratio control valves.

M-PAKT® may also be ordered as an EB model for use with a remote blower. EB M-PAKT® burners also include required fuel/air ratio control valves.

APPLICATION DETAILS

M-PAKT® Ultra Low NOx burner is suitable for use in industrial air heating, drying, baking and curing applications. The burner produces extremely low levels of NOx and CO for air quality compliance and end product sensitivities.

PROCESS TEMPERATURE

The M-PAKT® may be used in applications up to 1000°F . Consult page 1-1.7-15 for guidance on selecting proper burner configurations.

PROCESS FLOWS AND OXYGEN CONTENT

M-PAKT® burners may be applied in inert process streams as the burner supplies all the required air for combustion and the flame is fully contained in its discharge sleeve.

Process flows up to 2500 ft/m are allowed perpendicular to the discharge sleeve although this will affect emissions performance. For best emissions performance, limit the flow velocity at the burner's discharge to < 1000 ft/m . Protection plates or secondary sleeves are acceptable to limit the cross velocity.

PROCESS BACK PRESSURE

Packaged burner models with integral fan may be applied to applications with pressures between -4.0" wc and +2.0" wc .

EB models may be used for extended capacities or for higher application pressures. Consult MAXON for assistance with high back pressure applications.

PILOTING AND IGNITION

Ignition of M-PAKT® burners should be restricted to the pilot. While direct ignition may be possible, it is not recommended.

The M-PAKT® burner is provided with an independent pilot burner. The pilot should only be operated as interrupted or intermittent. Standing pilots are not permitted as the flame scanner will not distinguish between the pilot and main flame.

In low oxygen or high moisture applications, an air feed for the pilot may be used. Consult pages 1-1.7-8 to 1-1.7-12 for location and size of pilot air connections. Pilot air is not required in most applications.

RATIO CONTROL

For greater assurance of optimal emissions or for less stable application pressures, MAXON suggests the use of parallel positioning actuator systems. MAXON's SMARTLINK® MRV and Honeywell ControLinks™ provide high resolution control of the air and fuel valve for absolute control of air fuel ratio. The external control option allows the M-PAKT® burner to be used with an external air/fuel ratio control system such as SMARTFIRE™ .

Unlike inferior pressure regulators, high resolution parallel positioning provides absolute control even during transient conditions. This type of absolute control has proven to optimize efficiency while minimizing emissions of industrial burners.

M-PAKT® is not recommended for use with hi/lo or on/off control schemes.

COMBUSTION AIR CONTROL AND PIPING

Do not rotate combustion air blowers on packaged M-PAKT® burners. EB M-PAKT® burners require combustion air to enter the burner parallel to the burner's long axis.

FUELS

M-PAKT® burners provide low NOx performance on natural gas and propane only. Other clean fuel gases may be used in the burner, but performance and emissions may change.

EXPECTED EMISSIONS

In typical applications with specified excess air, the M-PAKT® Ultra Low NOx burner will produce only 5% to 10% of the NOx of conventional burners. CO is controlled to extremely low levels but varies according to the specific application parameters of each installation.

FLAME DEVELOPMENT

The flame of the M-PAKT® is entirely contained within the discharge sleeve of the burner making the effective flame length zero. Avoid locating the discharge of the burner close to walls, equipment or product as the exiting gases may be 2800°F or higher.

DISCHARGE SLEEVE RECOMMENDATIONS

Desired Excess Air Adjustment	Application Temperature	
	< 1000°F	1000°F - 1400°F
55 - 70%	OK	OK
40 - 55%	OK	Not recommended

FILTER/SILENCER

Optional round or square filter/silencer assemblies are available. Burner sound levels with and without silencer can be found in table on page 1-1.7-5. For dimensions, refer to pages 1-1.7-8 through 12.

DIMENSIONS

0.4M & 0.9M Packaged Burners - gas control method "S"

- 1) 1/8" NPT combustion air pressure test port
- 2) Observation port
- 3) Gas pressure test port
- 4) 1/4" NPT pilot gas inlet
- 5) Air pressure switch connection
- 6) Chamber pressure test port
- 7) Spark ignitor
- 8) Flame scanner connection 1" NPT-F
- 9) Gas inlet
0.4M - 1/2" NPT (F)
0.9M - 3/4" NPT (F)

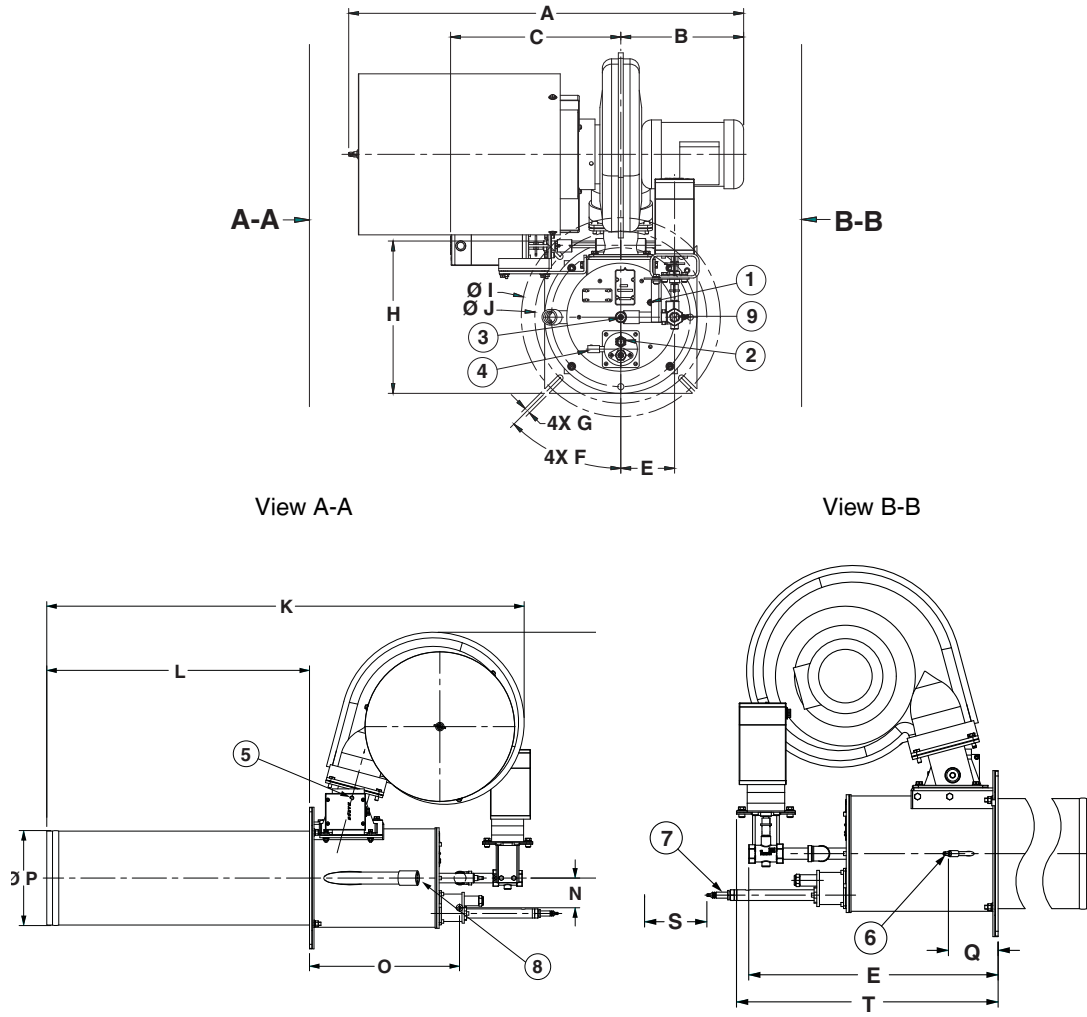

Dimensions in inches unless stated otherwise									
A	B	C	D	E	F	G slot	H square	I Ø	J Ø
40.19	12.5	17.32	5.47	23.29	45°	0.62	15.5	20.25	17.5

Dimensions in inches unless stated otherwise									
K	L	M	N	O	P Ø	Q	S	T	
52.2	28.75	26.9	3.25	16.44	10.4	4.6	28.0	24.5	

1.5M, 2.5M and 3.0M Packaged Burners - gas control method "S"

- 1) Chamber pressure test port
- 2) Air pressure switch connection
- 3) Gas pressure test port
- 4) Observation port
- 5) Combustion air pressure test port
- 6) 1/4" NPT pilot gas inlet
- 7) 1" NPT-F flame scanner connection
- 8) 1/2" NPT pilot air inlet (if required)
- 9) Spark ignitor
- 10) Gas inlet
 - 1.5M - 1" NPT (F)
 - 2.5M - 1-1/4" NPT (F)
 - 3.0M - 1-1/2" NPT (F)

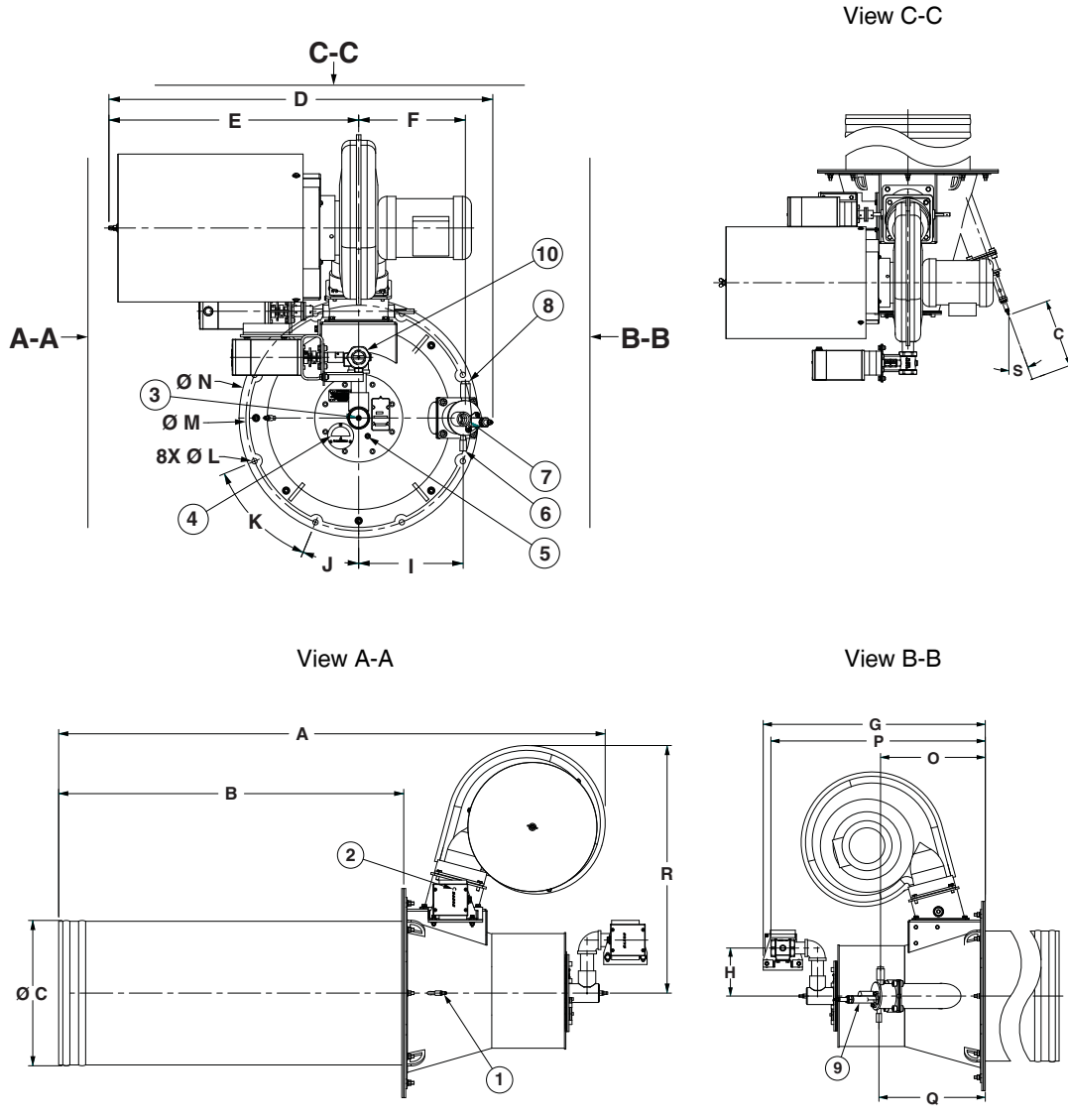

Dimensions in inches unless stated otherwise																	
A	B	C Ø	D	E	F	G	H	I	J	K	L Ø	M Ø	N Ø	O	P	Q	R
69.37	44.0	18.42	42.6	27.71	11.83	30.86	6.72	11.59	22.5°	45°	0.59	25.0	26.5	14.42	29.78	14.65	31.38

EB2 and EB3 (External Blower) Burners - gas control method "S"

- 1) 1/8" NPT combustion air pressure test port
- 2) 1/4" NPT pilot gas inlet
- 3) Gas pressure test port
- 4) Observation port
- 5) Air pressure switch connection
- 6) Spark ignitor
- 7) 1" NPT-F flame scanner connection
- 8) Chamber pressure test port
- 9) Gas inlet
EB2 - 1/2" NPT (F)
EB3 - 3/4" NPT (F)

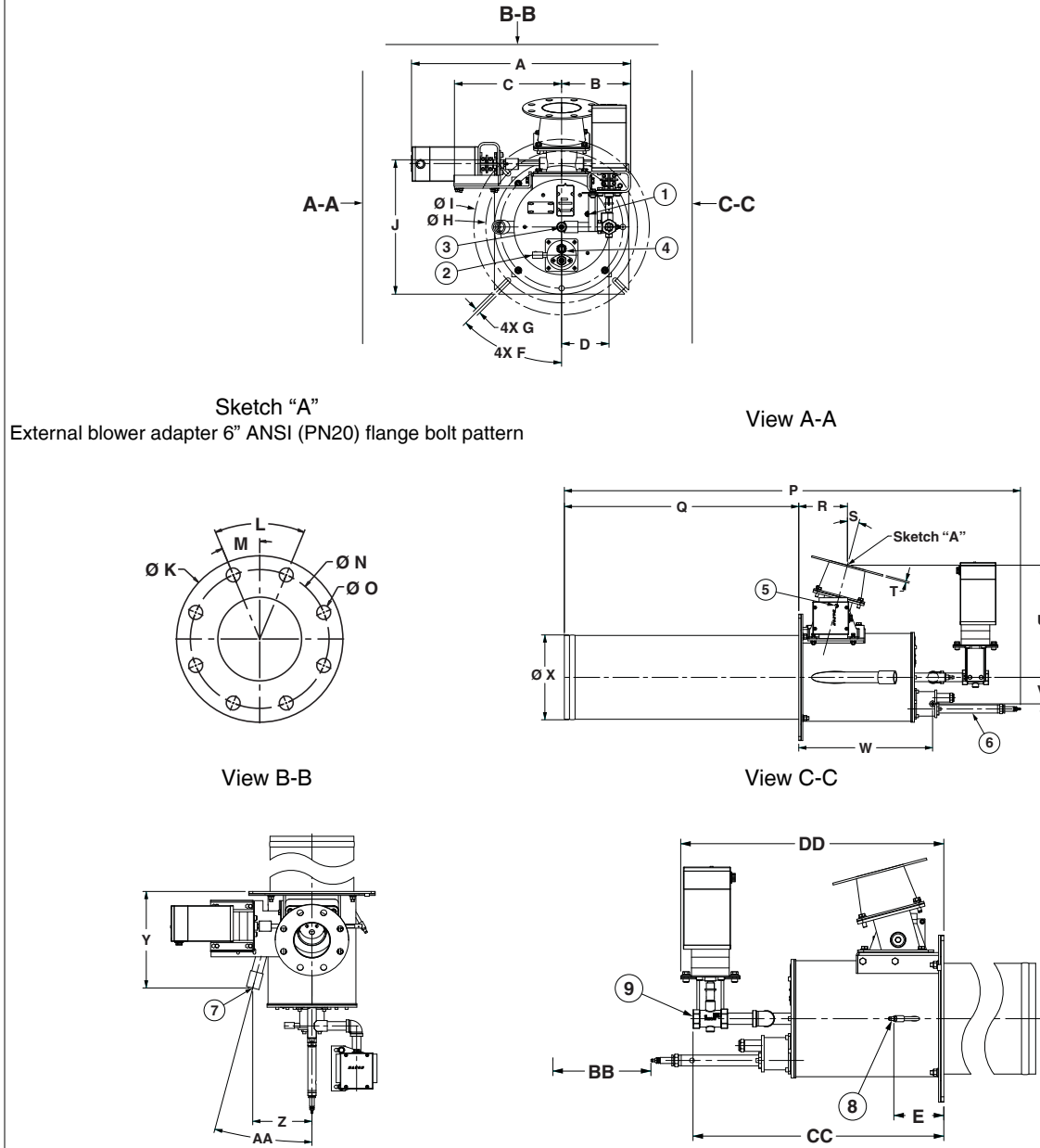

Dimensions in inches unless stated otherwise															
A	B	C	D	E	F	G slot	H Ø	I Ø	J	K Ø	L	M	N Ø	O Ø	P
25.29	8.0	12.37	5.47	4.6	45°	0.62	17.5	20.25	15.5	9.0	45°	22.5°	7.5	0.75	55.94

Dimensions in inches unless otherwise stated													
Q	R	S	T	U	V	W	X Ø	Y	Z	AA	BB	CC	DD
28.75	6.0	15°	0.18	13.75	3.25	16.44	10.4	11.8	7.28	15°	28.0	23.28	24.4

EB4, EB5, & EB6 (External Blower) Burners - gas control method "S"

- 1) Air pressure switch connection
- 2) Chamber pressure test port
- 3) Gas pressure test port
- 4) Observation port
- 5) Combustion air pressure test port
- 6) 1/4" NPT pilot gas inlet
- 7) 1" NPT-F flame scanner connection
- 8) 1/2" NPT pilot air inlet (if required)
- 9) Spark ignitor
- 10) Gas inlet
 EB4 - 1" NPT (F)
 EB5 - 1-1/4" NPT (F)
 EB6 - 1-1/2" NPT (F)

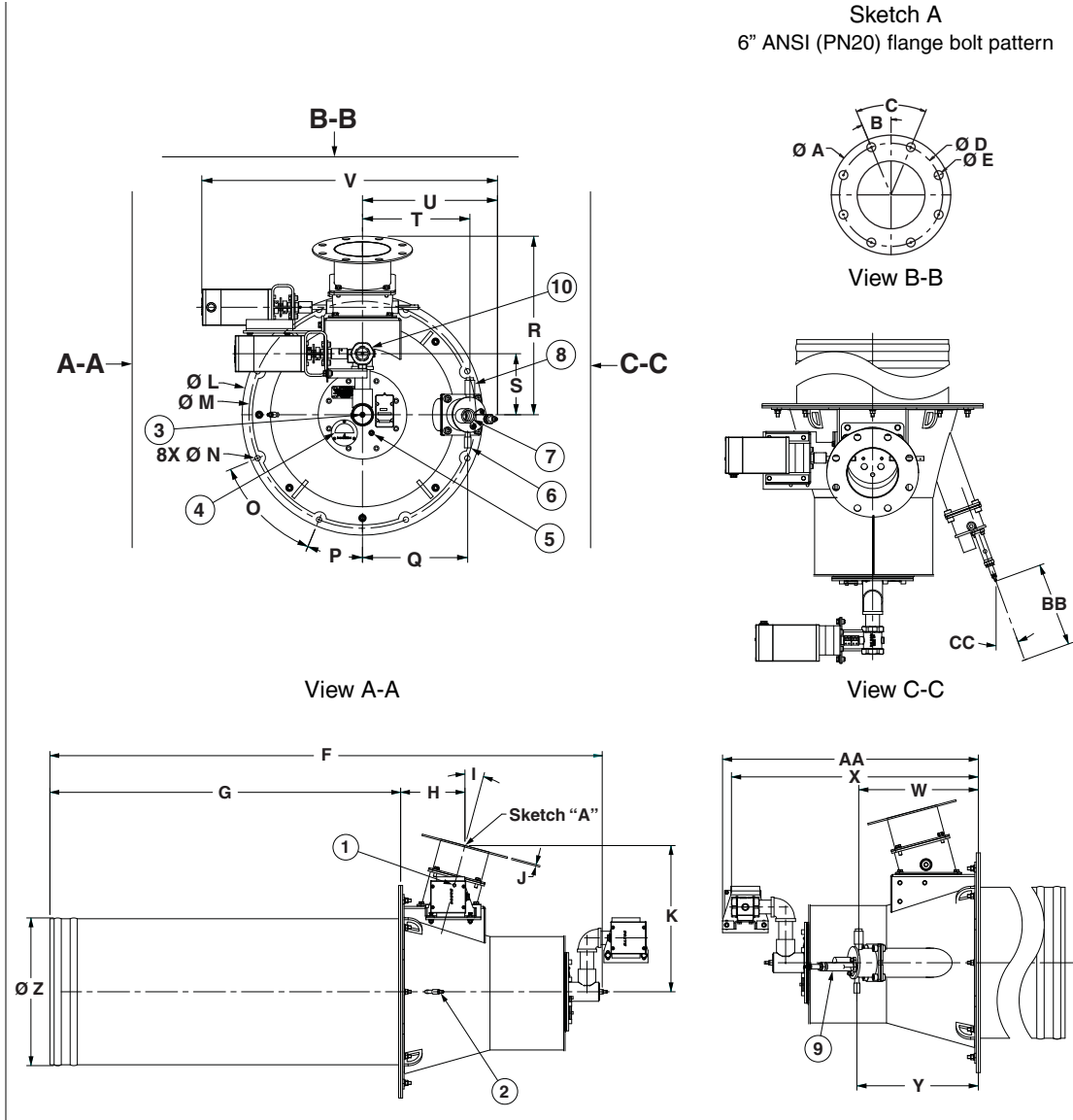

Dimensions in inches unless stated otherwise														
A Ø	B	C	D Ø	E Ø	F	G	H	I	J	K	L Ø	M Ø	N Ø	O
11.0	22.5°	45°	9.5	0.81	69.0	44.0	8.02	15°	0.18	18.23	26.5	25.0	0.59	45°

Dimensions in inches unless stated otherwise													
P	Q	R	S	T	U	V	W	X	Y	Z Ø	AA	BB	CC
22.5°	11.59	19.65	6.72	11.83	14.87	32.56	14.35	29.78 756	14.58	18.42	30.86	28	20°

EB7 (External Blower) Burners - gas control method "S"

- 1) Air pressure switch connection
- 2) Chamber pressure test port
- 3) Gas pressure test port
- 4) Observation port
- 5) Combustion air pressure test port
- 6) 1/4" NPT pilot gas inlet
- 7) 1" NPT-F flame scanner connection
- 8) 1/2" NPT pilot air inlet (if required)
- 9) Spark ignitor
- 10) Gas inlet 1-1/4" NPT (F)

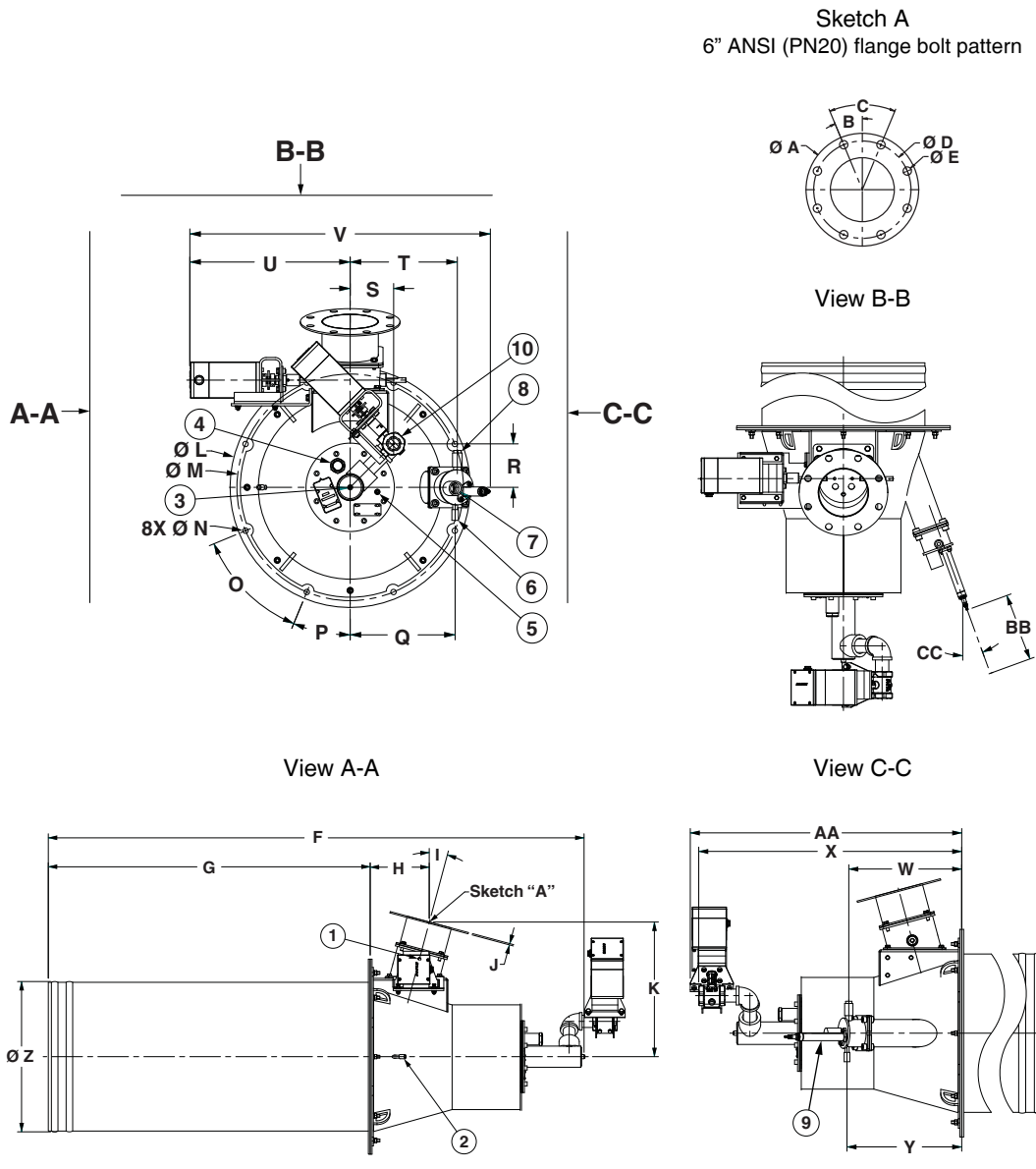

Dimensions in inches unless stated otherwise															
A Ø	B	C	D Ø	E Ø	F	G	H	I	J	K	L Ø	M Ø	N Ø	O	
11.0	22.5°	45°	9.5	0.81	72.8	44.0	8.02	15°	0.18	18.23	26.5	25.0	0.59	45°	

Dimensions in inches unless stated otherwise													
P	Q	R	S	T	U	V	W	X	Y	Z Ø	AA	BB	CC
22.5°	11.59	4.8	4.8	11.83	17.8	33.2	14.35	33.58	14.58	20.42	34.65	28.0	20°

Alternate gas control methods - gas control method “C”

0.4M & 0.9M HONEYWELL CONTROLINKS ACTUATOR WITH SQUARE FILTER/SILENCER OPTION

- 1) 1/8" NPT combustion air pressure test port
- 2) Observation port
- 3) Gas pressure test port
- 4) 1/4" NPT pilot gas inlet
- 5) Air pressure switch connection
- 6) Chamber pressure test port
- 7) Spark ignitor
- 8) Flame scanner connection 1" NPT-F
- 9) Gas inlet
0.4M - 1/2" NPT (F)
0.9M - 3/4" NPT (F)

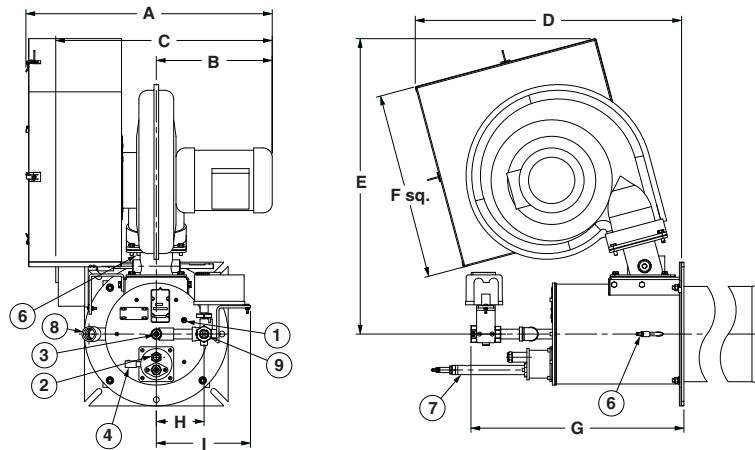

Dimensions in inches unless stated otherwise									
A	B	C	D	E	F square	G	H	I	
26.56	12.5	23.3	28.7	31.9	20	23.0	5.15	10.16	

1.5M, 2.5M & 3.0M HONEYWELL CONTROLINKS ACTUATOR WITH SQUARE FILTER/SILENCER OPTION

- 1) Chamber pressure test port
- 2) Air pressure switch connection
- 3) Gas pressure test port
- 4) Observation port
- 5) Combustion air pressure test port
- 6) 1/4" NPT pilot gas inlet
- 7) 1" NPT-F flame scanner connection
- 8) 1/2" NPT pilot air inlet (if required)
- 9) Spark ignitor
- 10) Gas inlet
1.5M - 1" NPT (F)
2.5M - 1-1/4" NPT (F)
3.0M - 1-1/2" NPT (F)

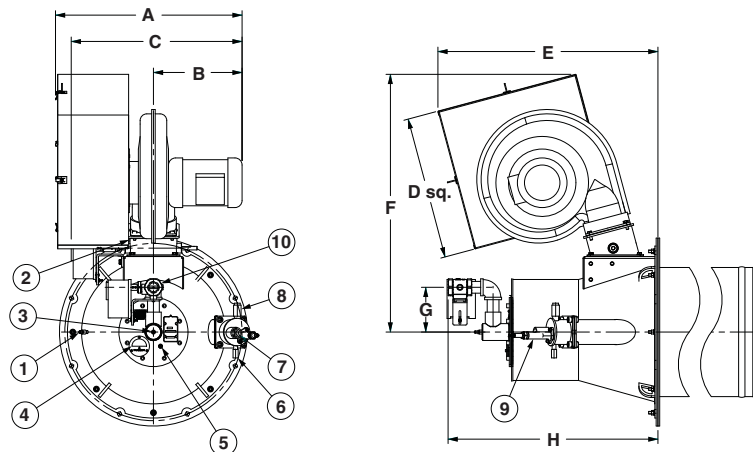

Dimensions in inches unless stated otherwise							
A	B	C	D square	E	F	G	H
26.31	12.5	24.09	20	31.0	36.3	6.31	29.6

Accessories and options

SPARK IGNITOR

- 1) Spark ignitor
- 2) Spark ignitor does not thread into this item. Slip fit.

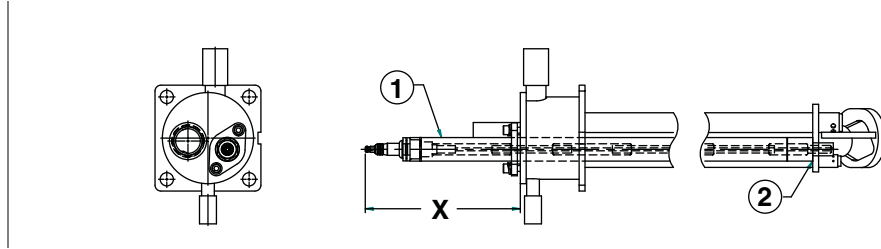

Dimensions in inches unless stated otherwise	
Burner size	Dimension X
0.4M & 0.9M	10.32
1.5M	8.89
2.5M	4.15
3.0M	5.84

FILTER/SILENCER

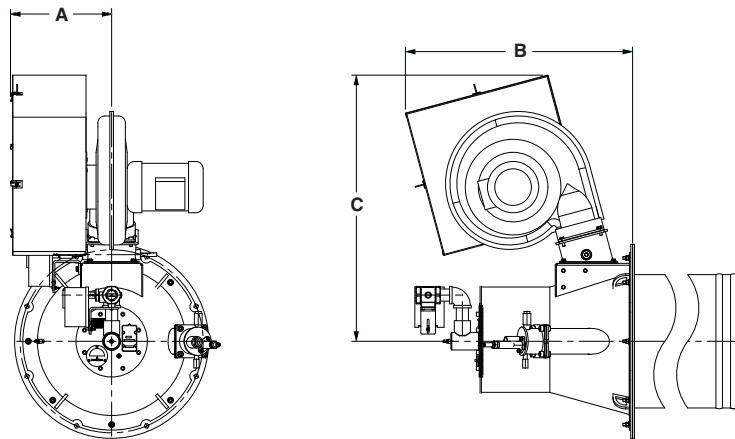

Dimensions in inches unless stated otherwise		
A	B	C
13.81	30.95	36.34

INSTALLATION AND OPERATING INSTRUCTIONS FOR M-PAKT® BURNERS

Application Requirements

VIEW PORT

A view port to observe burner flame is essential to inspect flame aspect. Locate the view port downstream of the flame, looking back to the burner block. Make sure the complete flame can be evaluated.

SUPPORT BURNER AIR AND GAS PIPING

The M-PAKT® Burner shall not be used as support for the piping to the burner. Gas and air piping shall be supported in such a way that no additional loads will be created on the burner.

BURNER MOUNTING FLANGE LOADS

Check burner weight and reinforce burner mounting flange or combustion chamber/furnace back wall if necessary to take complete burner weight.

RATIO CONTROL

M-PAKT® burners may be operated with 40 to 70% excess air. Consult page 1-1.7-7 for required sleeve materials per application.

MAXON recommends the use of characterized fuel/air ratio control through SMARTLINK MRV® or Honeywell ControLinks™. Consult MAXON for specific recommendations based upon the burner application and performance requirements.

FLAME SUPERVISION

M-PAKT® Burners require the use of UV or IR flame scanners. Some models of flame sensor may not respond well to ultra low NOx flame signatures. Consult sensor manufacturers for specific recommendations.

FUELS

M-PAKT® Burners are designed to operate on natural gas, propane and butane. Specific emissions performance can be affected by fuel. Contact MAXON for recommendations on alternative fuels.

Installation Instructions

STORAGE OF M-PAKT® BURNERS

M-PAKT® Burners shall be stored dry (inside).

HANDLING OF M-PAKT® BURNERS

M-PAKT® Burners are shipped as complete units. Handle burners with care during unpacking, transport, lifting and installation. Use proper equipment. Any impact on the burner could result in damage.

FLANGE THE BURNER TO THE INSTALLATION

Bolt the burner to the installation's burner mounting flange. Use proper gasketing. Tighten the flange bolting with correct torque. Retighten all bolts after first firing and regularly after commissioning.

CONTROL MOTOR INSTALLATION

Prior to control motor installation, remove the flexible coupling and place on control motor shaft. Mount control motor to bracket and air shaft.

START-UP INSTRUCTIONS FOR M-PAKT® BURNER

Read complete instructions before proceeding, and familiarize yourself with all the system's equipment components. Verify that your equipment has been installed in accordance with the original manufacturer's current instructions and complies with all applicable codes and standards.



CAUTION: Initial adjustment and light-off should be undertaken only by trained and experienced personnel familiar with combustion systems, with control/safety circuitry, and with knowledge of the overall installation. Instructions provided by the company and/or individuals responsible for the manufacture and/or overall installation of complete system incorporating MAXON burner take precedence over these provided by MAXON. If MAXON instructions conflict with any codes or regulations, contact MAXON before attempting start-up. Use only an interrupted pilot with the M-PAKT® burner. Do not use M-PAKT® burners with main gas shut off valves having extended opening times (> 6 seconds). Delayed introduction of main fuel can create strong light offs and thermal damage to burner internals.

TYPICAL IGNITION SEQUENCE

- Pre-purge of burner and installation, according to the applicable codes and the installation's requirements.
- Combustion air control valve shall be in the minimum position to allow minimum combustion air flow to the burner.
- Pre-ignition (typically 2 seconds sparking in air).
- Open pilot gas and continue to spark the ignitor (typically 5 seconds).
- Stop sparking, continue to power the pilot gas valves and start flame check. Trip burner if no flame from here on.
- Check pilot flame stability (typical 5 seconds to prove stable pilot).
- Open main gas valves and allow enough time to have main gas in the burner (typical 5 seconds + time required to have main gas in the burner).
- Close the pilot gas valves.
- Release to modulation (allow modulation of the burner).

Above sequence shall be completed to include all required safety checks during the start-up of the burner (process and burner safeties). Locate one pilot gas valve as close as possible to the pilot burner gas inlet to have fast ignition of the pilot burner.

SETTING APPROPRIATE FUEL PRESSURE AT ANY POINT

Step 1:

To properly adjust the fuel/air ratio of the M-PAKT® Burner at any firing rate, first measure the differential air pressure between the burner air test connection and the firing chamber.

Step 2:

Then multiply the air pressure value by the appropriate pressure factor, m, shown in the tables below.

Step 3:

Next, measure the fuel pressure differential between the burner fuel test connection and the firing chamber and adjust the fuel pressure with characterized fuel control valve at that point to the value calculated in Step #2.

Example:

On a 2.5M M-PAKT® Burner near half-fire, the differential air pressure reading is 2.2" wc . To figure the appropriate fuel pressure, multiply 2.2" wc by the m factor 0.99. The result is 2.18" wc . Set the differential fuel pressure to 2.18" wc .

Packaged Burners						
Size		0.4M	0.9M	1.5M	2.5M	3.0M
Max Capacity	MBtu/h	0.41	0.9	1.6	2.5	3.0
Max Fuel Pressure	" wc	4.1	10.4	8.6	10.3	9.5
Min Fuel Pressure	" wc	1.4	1.6	2.0	2.0	1.9
Max Air Pressure	" wc	8.8	8.8	10.1	10.4	9.4
Min Air Pressure	" wc	0.4	0.4	0.4	0.4	0.4
m	---	0.47	1.18	0.85	0.99	1.4

EB Burners							
Size		EB2	EB3	EB4	EB5	EB6	EB7
Max Capacity	MBtu/h	0.8	1.7	2.7	4.5	5.8	8.4
Max Fuel Pressure	" wc	12.1	37.2	24	32.6	37	60
Min Fuel Pressure	" wc	0.6	0.4	0.7	0.6	0.7	0.7
Max Air Pressure	" wc	29.4	29.7	28	32.9	27.5	27.2
Min Air Pressure	" wc	0.4	0.4	0.4	0.4	0.4	0.4
m	---	0.41	1.25	0.86	0.99	1.35	2.21

Fuel/Air Relationships - Packaged M-PAKT® Burner

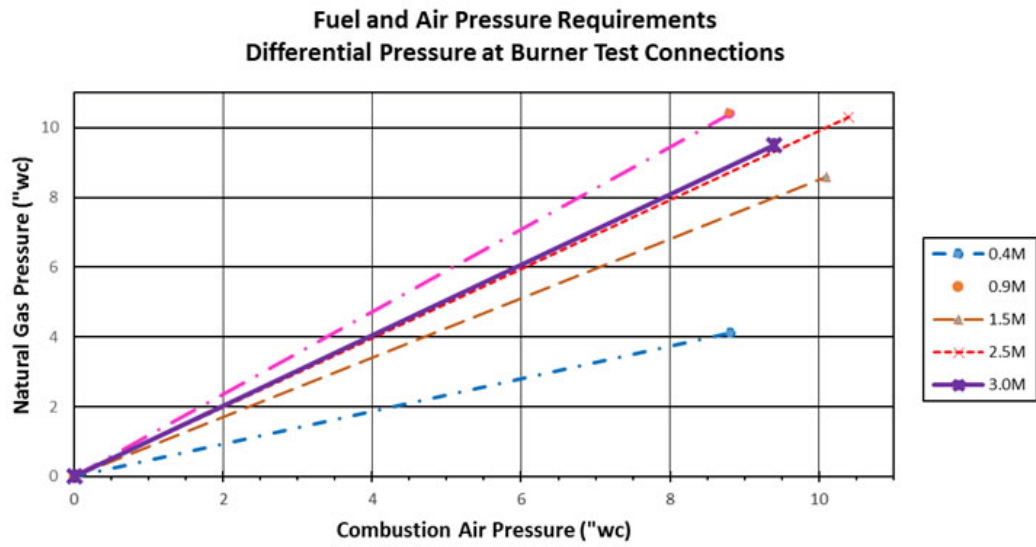

Fuel/Air Relationships - EB M-PAKT® Burner

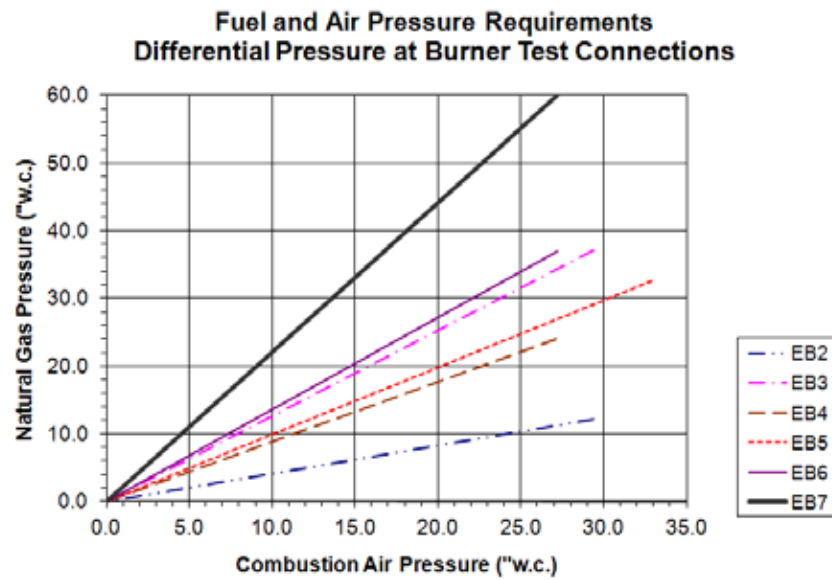

MAINTENANCE AND INSPECTION INSTRUCTIONS

SAFETY REQUIREMENTS

Regular inspection, testing and recalibration of combustion equipment according to the installation manual is an integral part of its safety. Inspection activities and frequencies shall be carried out as specified in the installation manual.

VISUAL INSPECTIONS

Regular visual inspection of all connections (air and gas piping to the burner, bolting of the burner to the furnace) and burner flame size and aspect are essential.

SPARE PARTS

Keep local stock of spark ignitor. It is not recommended to keep local stock of other burner parts. Consult installation manual for burner spare parts and system accessories.

Commercial & Industrial Combustion (C&I)

North America

MUNCIE, INDIANA, USA

Maxon

201 East 18th Street

P.O. Box 2068

Muncie, IN 47307-0068

Tel: 765.284.3304

Fax: 765.286.8394

GOLDEN VALLEY, MINNESOTA, USA

Honeywell Automation and Control Solutions

1985 Douglas Drive North

Golden Valley, MN 55422-3992

Canada Sales Office

Maxon Industrial Equipment

3333 Unity Drive

Mississauga, Ontario L5L 3S6

Tel: 800.489.4111

Fax: 855.262.0792

European Sales Office

Maxon International BVBA

Luchthavenlaan 16-18

1800 Vilvoorde, Belgium

Tel: 32.2.255.09.09

Fax: 32.2.251.82.41

Asia/Pacific Sales Office

Maxon

Honeywell Building

17 Changi Business Park, Central 1

Singapore 486073

Tel: 65.6580.3358

Fax: 65.6580.3345

China Sales Office

Maxon Combustion Equipment

(Shanghai) Co., Ltd.

1st Floor & Section A, 4th Floor

225 Meisheng Road

Wai Gao Qiao Free Trade Zone

Pudong New Area

Shanghai 200131, P.R. China

Tel: 86.21.5866.1166

Fax: 86.21.5868.1569

India Sales Office

Maxon

53, 54, 56, 57 Hadapsar Industrial Estate

Environmental & Combustion Controls

Sapphire Building 2nd Floor, A Wing

Pune 411013 India

Tel: 91.98.50907894

91.20.66008330

91.20.66008509

Sales Offices & Representatives Worldwide

www.maxoncorp.com

customer.honeywell.com

The Honeywell logo is displayed in a bold, red, sans-serif font. The letters are closely spaced and have a slight shadow effect, giving it a three-dimensional appearance. The logo is positioned in the bottom right corner of the page.