



# Minnox Burners

Version 1.00

PARAMETER	SPECIFICATIONS								
Heat input (based upon gross calorific values)	<table border="1" style="width: 100%; border-collapse: collapse;"> <tr> <td style="width: 50%;">Straight 150 mm section</td> <td>135 kW (460,000 Btu/hr.)</td> </tr> <tr> <td>T - section</td> <td>540 kW (1,844,000 Btu/hr.)</td> </tr> <tr> <td>Cross section</td> <td>675 kW (2,305,000 Btu/hr.)</td> </tr> </table>	Straight 150 mm section	135 kW (460,000 Btu/hr.)	T - section	540 kW (1,844,000 Btu/hr.)	Cross section	675 kW (2,305,000 Btu/hr.)		
Straight 150 mm section	135 kW (460,000 Btu/hr.)								
T - section	540 kW (1,844,000 Btu/hr.)								
Cross section	675 kW (2,305,000 Btu/hr.)								
Standard compliance	EN746-2 : 1997								
Turndown	10 : 1								
Fuel	Natural gas (H) Propane (<10% unsaturated) Butane (<10% unsaturated) Contact Eclipse for other fuels								
Combustion air	<table border="1" style="width: 100%; border-collapse: collapse;"> <tr> <td style="width: 30%;">Volume:</td> <td>205 m<sup>3</sup>/h per 135 kW (120 scfm per 460,000Btu/hr)</td> </tr> <tr> <td>Approx. Pressure:</td> <td>48 mbar at mixer inlet, neutral chamber pressure (19.3" w.c.)</td> </tr> <tr> <td>Temperature:</td> <td>40° C maximum (104° F)</td> </tr> </table>	Volume:	205 m <sup>3</sup> /h per 135 kW (120 scfm per 460,000Btu/hr)	Approx. Pressure:	48 mbar at mixer inlet, neutral chamber pressure (19.3" w.c.)	Temperature:	40° C maximum (104° F)		
Volume:	205 m <sup>3</sup> /h per 135 kW (120 scfm per 460,000Btu/hr)								
Approx. Pressure:	48 mbar at mixer inlet, neutral chamber pressure (19.3" w.c.)								
Temperature:	40° C maximum (104° F)								
Gas pressure at proportionator inlet	Minimum 100 mbar (40" w.c.) Maximum 300 mbar (120" w.c.)								
Burner start input	20% of nominal input								
Pilot, Integral, nozzle mixing, spark ignited	15kW (51,000 Btu/hr.) Interrupted Pilot								
Pilot Gas Pressure	Minimum 16 mbar (6.5" w.c.) Maximum 28 mbar (11" w.c.)								
Flame monitoring	U.V. Scanner								
High fire flame length	Approximately 300 mm (12") measured from the whirl plate, firing parallel to the process air flow with neutral chamber pressure. The flame is completely protected by a heat-resistant steel combustion chamber with a length of 400 mm (16").								
Emissions at 3% oxygen	NO <sub>x</sub> less than 5 ppm at nominal input CO less than 30 ppm. HCHO aldehydes: (no smell in undiluted flue gases.) < 0.17 ppm								
Ambient temperature limits	This is determined by the monitoring and control equipment such as UV scanners, automatic fuel shut-off valves and electrical wiring.								
Process conditions	<table border="1" style="width: 100%; border-collapse: collapse;"> <tr> <td style="width: 30%;">Inlet temperature:</td> <td>300° C maximum (570° F)</td> </tr> <tr> <td>Outlet temperature:</td> <td>500° C maximum (930° F)</td> </tr> <tr> <td>Negative pressure:</td> <td>6 mbar maximum (2.4" w.c.)</td> </tr> <tr> <td>Positive pressure:</td> <td>10 mbar maximum (4" w.c.)</td> </tr> </table>	Inlet temperature:	300° C maximum (570° F)	Outlet temperature:	500° C maximum (930° F)	Negative pressure:	6 mbar maximum (2.4" w.c.)	Positive pressure:	10 mbar maximum (4" w.c.)
Inlet temperature:	300° C maximum (570° F)								
Outlet temperature:	500° C maximum (930° F)								
Negative pressure:	6 mbar maximum (2.4" w.c.)								
Positive pressure:	10 mbar maximum (4" w.c.)								
Process air velocity past the burner	20 m/s (3900 fpm) maximum, 2 m/s (390 fpm) minimum Recommended velocity 12 m/s (2400 fpm) WARNING: Velocity perpendicular to the flame direction is not allowed.								
Process air ΔP (estimated)	At 10 m/s velocity: 0,5 mbar. (1950 fpm: 0.2" w.c.) At 20 m/s velocity: 2,0 mbar. (3900 fpm: 0.8" w.c.)								

• All inputs based upon standard conditions; 1 atmosphere, 21°C (70° F).  
Eclipse reserves the right to change the construction and/or configuration of this product at any time without being obliged to adjust earlier supplies accordingly.

Minox burner systems are typically supplied as packaged units with heat inputs from 125 kW to 7000 kW (.5MM Btu/hr. to 24MM Btu/hr.) including the burner, mixer and valve trains mounted to a duct section or side-plate arrangement for installation into the process ductwork. For a detailed, (application specific) system design, contact Eclipse Combustion or your local Eclipse representative.

**Firing Arrangements**

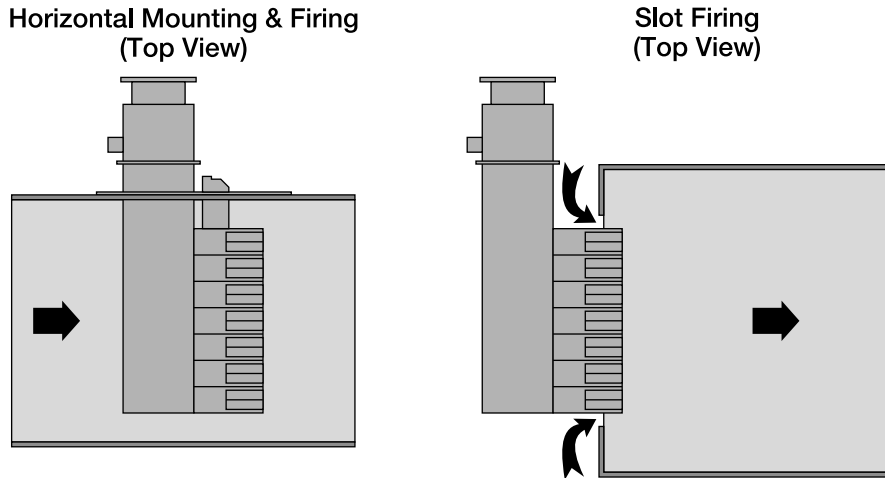

Burners can be configured to fire vertically (up or down) or horizontally (left or right). Systems include complete duct mounted burner sections, side-plate assemblies for insertion into an existing duct and designs for slot firing into an existing duct. "T" section and "Cross" section burner heads are also available to optimize heat distribution patterns within the duct.

**Good Duct Design**

The Minox duct / side-plate unit must be properly installed in the process air duct system so that the process air velocity past the burner remains uniform. The illustrations below represent good duct designs which will best maintain the process air velocity. The black area represents the Minox burner.

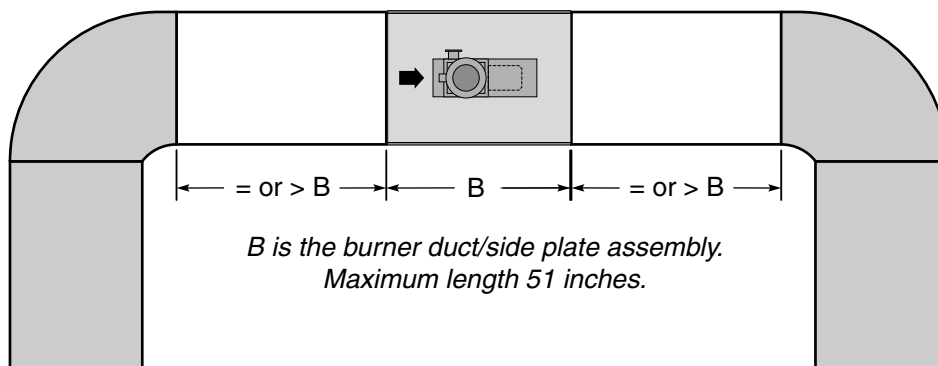
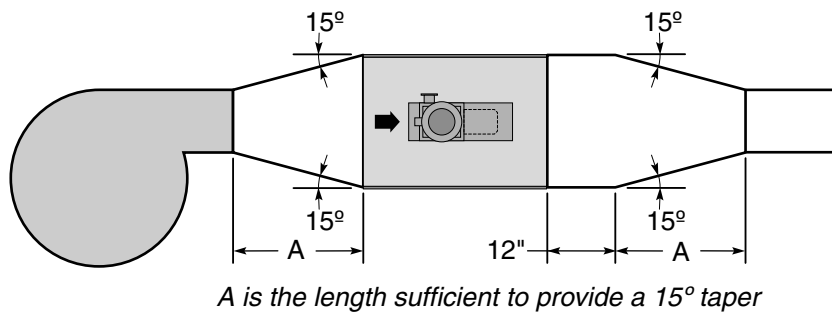

## Typical System

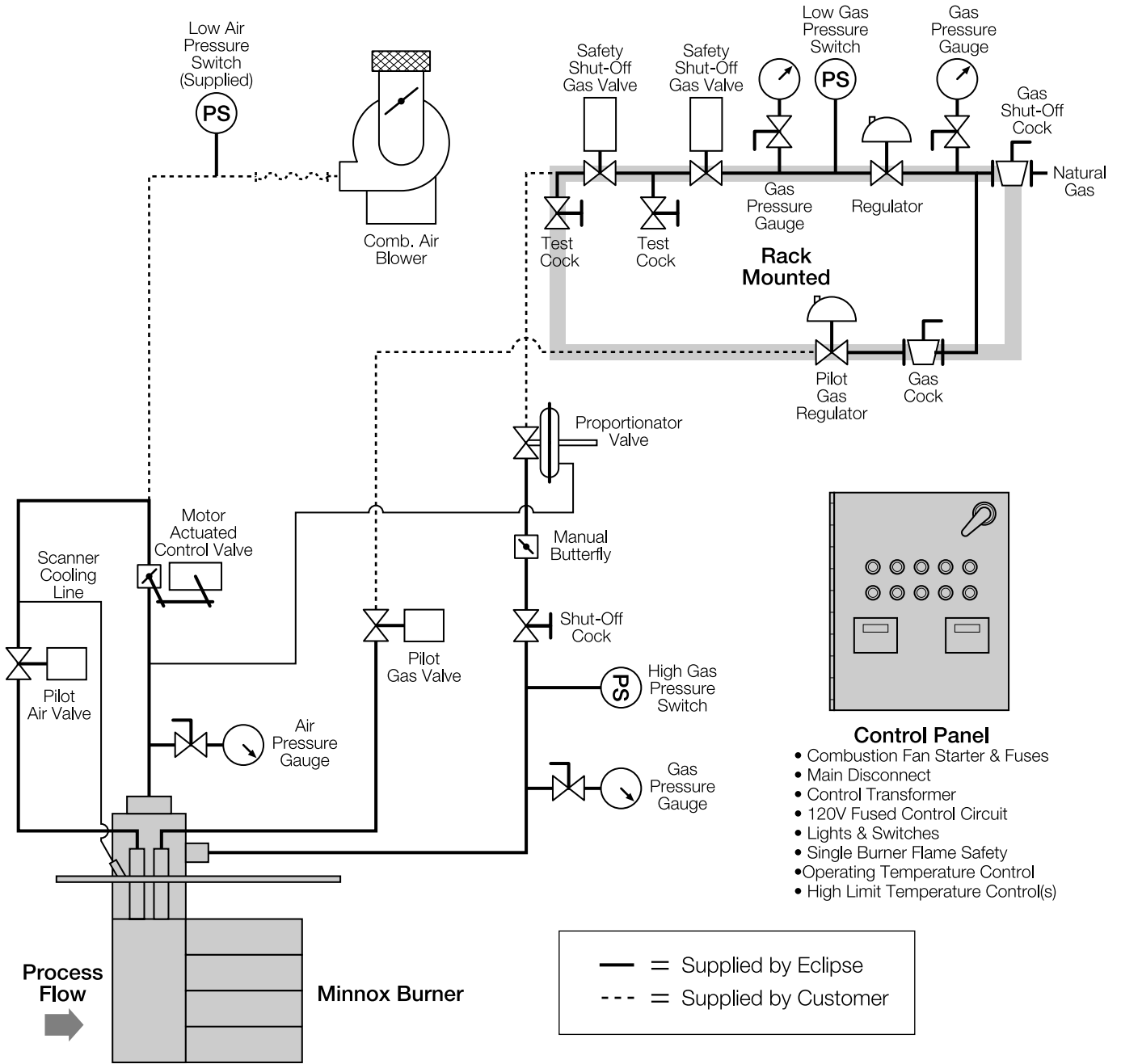

## Pilot Options

**Option A**  
Recommended for Fresh Air Systems

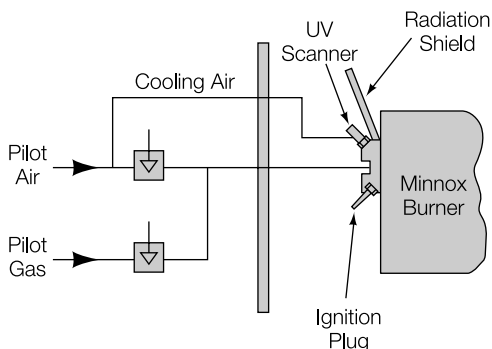

**Option B**  
Recommended for all Recirculation Systems

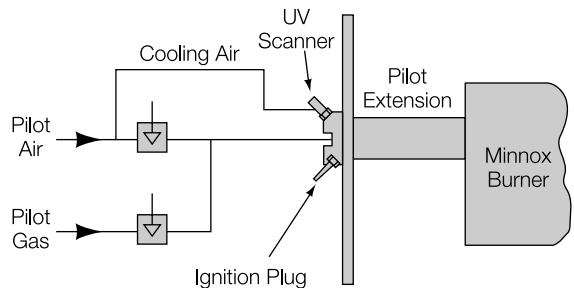

## General Dimensions – Straight Sections (For Estimating Purposes Only)

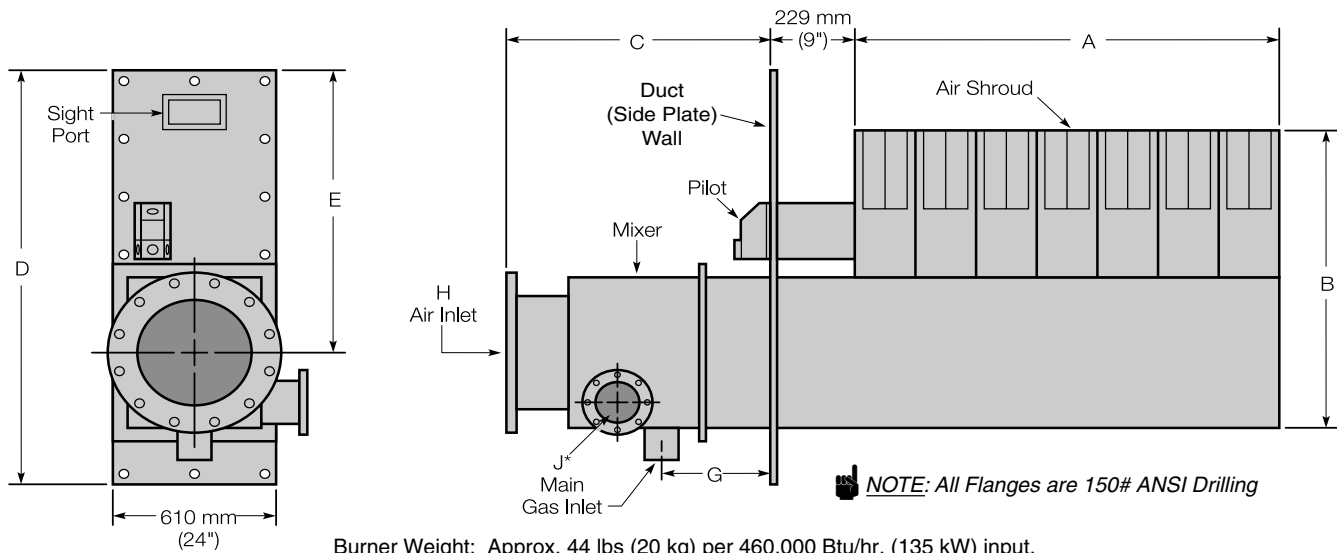

Burner Weight: Approx. 44 lbs (20 kg) per 460,000 Btu/hr. (135 kW) input.  
Weight includes mixer and mounting plate but not the combustion air blower.

Model	A		B		C		D		E		G		H (In.)	J* (In.)
	mm	In.	mm	In.	mm	In.	mm	In.	mm	In.	mm	In.		
125	152	6	533	21	432	17	1016	40	610	24	229	9	4	1
250	305	12	533	21	432	17	1016	40	610	24	229	9	6	1
375	457	18	533	21	432	17	1016	40	610	24	229	9	6	1.5
500	610	24	533	21	432	17	1016	40	610	24	229	9	6	1.5
625	762	30	686	27	483	19	1016	40	686	27	254	10	10	1.5
750	914	36	686	27	483	19	1016	40	686	27	254	10	10	1.5
875	1067	42	686	27	483	19	1016	40	686	27	254	10	10	2
1000	1219	48	686	27	483	19	1016	40	686	27	254	10	10	2
1125	1372	54	686	27	483	19	1016	40	686	27	254	10	10	2
1250	1524	60	686	27	483	19	1016	40	686	27	254	10	10	2
1375	1676	66	838	33	483	19	1270	50	762	30	254	10	12	2
1500	1829	72	838	33	483	19	1270	50	762	30	254	10	12	2.5
1625	1981	78	838	33	483	19	1270	50	762	30	254	10	12	2.5
1750	2134	84	838	33	483	19	1270	50	762	30	254	10	12	2.5
1875	2286	90	838	33	483	19	1270	50	762	30	254	10	12	2.5
2000	2438	96	838	33	483	19	1270	50	762	30	254	10	14	2.5
2125	2591	102	838	33	483	19	1270	50	762	30	254	10	14	3
2250	2743	108	838	33	483	19	1270	50	762	30	254	10	14	3
2375	2896	114	965	38	533	21	1270	50	838	33	254	10	16	3
2500	3048	120	965	38	533	21	1270	50	838	33	254	10	16	3
2625	3200	126	965	38	533	21	1270	50	838	33	254	10	16	3
2750	3353	132	965	38	533	21	1270	50	838	33	254	10	16	3
2875	3505	138	965	38	533	21	1270	50	838	33	254	10	16	4
3000	3658	144	965	38	533	21	1270	50	838	33	254	10	16	4
3125	3810	150	1143	45	533	21	1499	59	838	33	254	10	16	4
3250	3962	156	1143	45	533	21	1499	59	914	36	254	10	16	4
3375	4115	162	1143	45	533	21	1499	59	914	36	254	10	16	4
3500	4267	168	1143	45	533	21	1499	59	914	36	254	10	16	4
3625	4369	172	1143	45	533	21	1499	59	914	36	254	10	16	4
3750	4521	178	1270	50	737	29	1499	59	991	39	254	10	18	4
3875	4674	184	1270	50	584	23	1499	59	991	39	254	10	18	4
4000	4826	190	1270	50	584	23	1499	59	991	39	254	10	18	4

\* There are two main gas inlets shown—all model numbers below 2000 have the N.P.T. threaded inlet. All others have the flanged inlet.



**Eclipse Combustion**  
www.eclipsenet.com